



---

DRAIN COMMISSIONER

---

*Jeffrey Wright*

**STANDARD SPECIFICATIONS & DETAILS  
FOR  
SOIL EROSION & SEDIMENTATION CONTROL (SESC)**



SECOND EDITION  
2017

GENESEE COUNTY DRAIN COMMISSIONER'S OFFICE  
DIVISION OF WATER AND WASTE SERVICES  
G-4610 BEECHER ROAD  
FLINT, MI 48532  
(810) 732-7870  
[www.gcdcwws.com](http://www.gcdcwws.com)

## **INTRODUCTION**

The purpose of this specification is to provide guidelines for proper implementation of Soil Erosion and Sedimentation Control (SESC). All proposed measures on the plans should reflect these changes to these details. GCDC-WWS also has included supplemental data from other sources for calculation purposes, appropriate seed type and any other information that GCDC-WWS is requiring to be implemented for SESC.

## TABLE OF CONTENTS

### PART 1 – OVERVIEW

<u>Section</u>	<u>Title</u>	<u>Pages</u>
A	Preamble	1
B	General	1-3
C	Soil Erosion and Sedimentation Control Requirements	3-4
D	Planning and Design Considerations	4-5

### PART 2 – SEEDING AND SOIL SUPPLEMENTS

<u>Section</u>	<u>Title</u>	<u>Pages</u>
A	Quality Assurance	1
B	Definitions & Terminology	1-2
C	Regulatory Requirements	2
D	Delivery, Storage, and Handling	2
E	Soil Materials	2-3
F	Tests	3
G	Examination	3
H	Preparation of Subsoil	4
I	Placing Topsoil	4
J	Fertilizing	4-5
K	Seeding Mixtures, Rates, and Dates	5-7
L	Accessories	7
M	Hydroseeding	7-8

## **PART 2 – SEEDING AND SOIL SUPPLEMENTS**

<u>Section</u>	<u>Title</u>	<u>Pages</u>
N	Sod	8-9
O	Seed Protection	9
P	Maintenance	9-10

## **PART 3 – MICHIGAN UNIFIED KEYING SYSTEM**

### **PART 4 – DETAILS**

1	Dust Control
2	Selective Grading and Shaping
3	Grubbing Omitted
4	Vegetative Stabilization
5	DETAIL INTENTIONALLY LEFT BLANK
6	Seeding with Mulch Blanket and/or Matting
7	DETAIL INTENTIONALLY LEFT BLANK
8	Sodding
9	Vegetative Buffer Strip
10	Mulching
11	Roughened Surface
12	DETAIL INTENTIONALLY LEFT BLANK
13	Rip Rap, Rubble, Gabions
14	DETAIL INTENTIONALLY LEFT BLANK
15	DETAIL INTENTIONALLY LEFT BLANK
16	DETAIL INTENTIONALLY LEFT BLANK

## **PART 4 – DETAILS**

<b>Section</b>	<b>Title</b>
17	Benches
18	Earth Diversion Berm
18A	Earth Diversion Berm with Stone Outlet Filter
19	Diversion Ditch
20	Diversion Berm and Ditch
21	Stone Filter Berm
21A	Stone Filter Berm with Silt Fence
22	DETAIL INTENTIONALLY LEFT BLANK
23	DETAIL INTENTIONALLY LEFT BLANK
24	Grassed Waterway
25	Slope Drain - Surface Pipe
26	Slope Drain - Paved Chute/Flume
27	Slope Drain - Subsurface Pipe
28	Drop Spillway
29	Pipe Drop
30	Pipe Spillway
31	Energy Dissipater
32	Level Spreader
33	Sediment Trap
34	Sediment Basin
35	DETAIL INTENTIONALLY LEFT BLANK
36	Catch Basin Inlet Protection

## **PART 4 – DETAILS**

<b>Section</b>	<b>Title</b>
37	Sod Filter
38	DETAIL INTENTIONALLY LEFT BLANK
39	Fabric Filter Curb Inlet Protection
40	Inlet Sediment Trap
41	Stone and Rock Ford Crossing
42	Temporary Culvert
43	Culvert Sediment Trap
44	DETAIL INTENTIONALLY LEFT BLANK
45	Temporary Stream Channel Change
46	DETAIL INTENTIONALLY LEFT BLANK
47	Cofferdam
48	DETAIL INTENTIONALLY LEFT BLANK
49	Check Dam
50	DETAIL INTENTIONALLY LEFT BLANK
51	Retaining Wall
52	DETAIL INTENTIONALLY LEFT BLANK
53	Wind Break
54	Silt Fence
55	Stone Inlet - Before Paving
55A	Stone Inlet - After Paving
56	DETAIL INTENTIONALLY LEFT BLANK

## **PART 4 – DETAILS**

<b>Section</b>	<b>Title</b>
57	Stream Liner
58	Sediment Sump
59	DETAIL INTENTIONALLY LEFT BLANK
60	Temporary Gravel Construction Entrance

## **PART 5 – ADDITIONAL TABLES**

Table 1	Seeding Dates for Permanent Mixtures
Table 2	Seeding Dates for Native Grasses
Table 3	Seeding Dates and Rates for Temporary Cover Crops
Table 4	Example Seeding Mixture for Introduced Species
Table 5	Seed Selection Guide for Custom Mixtures of Introduced Species
Table 5B	Creating a Custom Seed Mixture
Table 6	Seed Selection Guide for Some Commonly Available Native Grasses

# **PART 1: OVERVIEW**



## **PART 1: OVERVIEW**

### **A. PREAMBLE**

The Genesee County Drain Commissioner's Office— Division of Water and Waste Services (GCDC-WWS) has been granted authority to administer and enforce Part 91, Soil Erosion and Sedimentation Control (SESC), of the Natural Resources and Environmental Protection Act 451 of 1994. The Genesee County Board of Commissioners designated GCDC-WWS, by resolution, as the County Enforcing Agency (CEA). (See attached Resolution dated March 12, 2002). The CEA is responsible for controlling soil erosion and sedimentation for any earth change activity that is not exempt from obtaining a permit, pursuant to the above-mentioned Act. The specifications set forth in this document shall be utilized to control onsite erosion and prevent offsite sedimentation.

### **B. GENERAL**

As defined in the Part 91 of P.A. 451, soil erosion is defined as the wearing away of land by the action of wind, water and gravity. Once this soil has been dislodged, it may be transported via the methods of displacement. Erosion from the runoff of water can be broken down into three categories: sheet erosion, rill erosion and gully erosion. Of the three, sheet erosion is the most common and is the precursor to both rill and gully erosion. Because of the cohesive nature of water, rills form where small pockets of runoff concentrate. These rills are generally uniform on a slope. If there is enough concentrated runoff, however, rill erosion can lead to gully erosion. Once the soil has been eroded and the action force that moved it ceases, sediment is deposited. The process of erosion and deposition of sediment is a natural process and has shaped the landscape that we live on. When land is stripped of vegetation, construction, deforestation and other land use activities, accelerated soil erosion occurs, which can result in 100 to 1000 times the natural amount of soil loss.

Soil loss of this magnitude has a significant impact on one of Michigan's most valuable resources: Waters of the State. Waters of the State can be defined as inland lakes and streams as defined under Part 301 of P.A. 451 and wetlands defined under Part 303 of P.A. 451. The sediment added to the Waters of the State via sedimentation reduces the water quality by an increase in turbidity. Turbid water will generally have a higher temperature than clear water, due to solar heating. An increase in water temperature can deplete the environment of certain species of fish and other aquatic life. Moreover, the heavier sediments glut stream channels, decreasing their capacities to contain larger flows and promote flooding. These heavier sediments that fill stream channels can also eliminate spawning area for certain species of aquatic life.

There are four major factors that influence erosion: vegetation, slope, soil type and climate.

- (a) *Vegetation* - Of the four factors, vegetation is the single most important control of soil erosion. The foliage intercepts and reduces the force delivered by raindrops. Roots bind the soil together, making it more resistant to erosion. The more dense the vegetation, the more resistant it is to erosion.
- (b) *Slope* - The steepness, shape and length of a slope have a significant impact for potential erosion. The steeper and longer the slope, the higher the velocity of runoff will be. The shape of the slope also influences the potential for erosion. Uniform slopes generally will have sheet or rill erosion. Slopes that converge and concentrate runoff have the highest propensity of erosion, usually resulting in rill erosion to gully erosion. Slopes that diverge runoff will most likely have much less erosion but will still have sheet and possible rill erosion.
- (c) *Soil Type* - Sands, silts and clay react differently to the runoff of water. Sandy soils are coarse and tend not to hold much water. Sand is the easiest to erode because of its relative size and lack of cohesiveness. Sands are the first to settle out of a water column when the velocity of water is reduced. Clay soil is very fine and retains water. Clays soils are cohesive and require higher velocities than sand for clay to erode. Once in the water column though, clays are difficult to settle out unless ponded for a great amount of time. Silt soils fall between sand in clays in relative size. Silts are not as easily erodible as sand but more so than clay. Silts take settle out of a water column quicker than clay but not as quick as sand. Organic matter, not a soil type, should be included because it help bind the soil together, allowing more water to infiltrate and reducing erosion. These soil types rarely exist by themselves, generally a mixture of the three types plus organic matter.
- (d) *Climate* - Climate can be broken down into the amount, intensity and frequency. The amount of rain is measured in inches. The intensity is measured in the amount of rainfall in inches fallen in an hour. The frequency of rainfall depends upon the amount of rain for all separate rain events over a certain amount of time. Two things happen to the soil when hit by rainfall. Water not intercepted by vegetation will infiltrate into the soil. If the holding capacity of the soil is exceeded and saturated, the remaining rainfall amount then will convert into runoff. The higher amount of runoff leads to increased velocities of water, which causes greater erosion potential.

These four factors need to be determined whenever dealing with either natural or accelerated soil erosion. In the case of accelerated soil erosion, it is important to identify critical areas and sensitive areas. Erosion should be controlled on the site, which in turn will limit sediment from entering Waters of the State or off of the site.

## C. SOIL EROSION AND SEDIMENTATION CONTROL REQUIREMENTS

### PERMITS AND WAIVERS

The GCDC-WWS requires all proposed earth changes to be reviewed for SESC. During the review process, if GCDC-WWS determines that the earth change exceeds an acre in size or is within 500 feet of an inland lake or stream, then a SESC Permit will be required for that earth change.

GCDC-WWS may consider a SESC Waiver for the following earth change activity scenarios:

- If the earth change does not exceed one (1) acre in size and is a distance greater than 500 feet from an inland lake and stream.
- If a particular proposed earth change that would normally require a SESC Permit will be stabilized within a 24 hour period of initial disturbance.
- If the earthwork activity is less than 225 square feet in size.

Please reference the new SESC Procedures PPC 12-001 and PPC 12-002.

### BUILDING PERMITS

All local municipalities shall require either a SESC Permit or Waiver for an earthwork activity prior to issuing a building permit. An excerpt from the MDEQ administrative rules for SESC:

*“R 323.1711 (2) A local agency or general law township shall not issue a building permit to a person engaged in an earth change if the change requires a permit under part 91 or these rules until the county or local enforcing agency has issued the required state-prescribed permit for the earth change.”*

The office of GCDC-WWS shall determine if such earthwork activity requires a SESC Permit or Waiver.

### COMMERCIAL AND RESIDENTIAL PERMITS

All projects shall be designated either a residential or commercial projects. The initial installation of infrastructure for a residential development shall be permitted as a commercial development. Site condominiums and platted subdivisions shall have a residential permit for each individual home on a lot/unit. The construction of homes for a condo project shall be incorporated into the initial development, since the land of this type of project will not be subdivided in the future. All commercial projects shall have a non-expiring SESC bond active for the duration of the project and is based on the size of the earth change measured in acres. All residential projects shall have a non-expiring

SESC bond active for the duration of the project if and only if the work is being done by a hired Contractor.

### APPLICATION AND REVIEW PROCESS

A completed Soil Erosion and Sedimentation Control Application package shall be completed and submitted to GCDC-WWS to start the review process. This package shall include the application, construction and maintenance schedule, checklist and SESC Plan for a timely review. It is important that these forms are complete, as it will influence the amount of effort to review and permit the project. If an earth change is proposed in areas considered Waters of the State or within the 100-year floodplain, copies of all local, state and federal permits authorizing such activities shall be attached with the package. A well-prepared SESC Plan will enable GCDC-WWS to perform its review with a quick turn-around time. Please reference the new SESC Procedures PPC 12-001 and PPC 12-002.

### **D. PLANNING AND DESIGN CONSIDERATIONS**

It is vitally important that proper planning be utilized for the design of a SESC plan. The checklist provided by this office shall be followed in its entirety. This information identified on the plan, allows all critical, non-critical and sensitive areas to be identified.

Some key points to keep in mind when creating:

- a. Is erosion being controlled on site?
- b. Are Waters of the State adequately protected from sediment?
- c. Are appropriate measures being proposed to keep sediment onsite?

With these principles in mind, the plan preparer can best assess the staging of the project as well as what temporary and permanent measures to use. Most sites are unique and the proposed SESC measures should reflect that. The disturbed areas should be kept to a minimum; work shall be performed only in areas that are necessary for each stage in construction. Earth changes shall be avoided in critical areas whenever possible. These areas can have the most impact upon proposed temporary measures and are the most difficult to stabilize. All sensitive areas shall be protected from erosion and sedimentation.

The time of the year of the proposed earth change needs to be considered during the planning process. While the frost is in effect, the ground is less susceptible to erosion. However, during the thaw, the surface is most susceptible to runoff due to ground saturation and early spring rain events. Dust control is also needed typically during the dry months of the summer, but can occur at any time. A lack of precipitation, coupled with dry disturbed soils, necessitates measures to control dust.

Planning and timing are important to minimize the amount of exposed soil that can potentially erode and transport sediment. The less time that a site is disturbed equates to a lower potential for onsite erosion and offsite sedimentation. Temporary measures are only

designed for a 10-year frequency storm. Storms larger than these render temporary measure obsolete and inoperable. Temporary measures must be inspected, maintained and be able to handle a ten-year storm even at all times. Proper inspection and maintenance to all temporary measures will lessen the impact to the environment for a larger rain event than the measures were designed for. The less time that a site has disturbed soil, the less likely that such a rain event will occur while that site is disturbed.

With solid planning, unforeseen events/conditions can change the way a successful SESC Plan functions onsite that could require modification to the plan. For example, during the course of construction, the transition of existing grade to proposed grade could make a temporary measure inadequate, requiring an alteration to the onsite measures being utilized. In any case, GCDC-WWS will require changes to any project where the proposed measure(s) (temporary and/or permanent) are not working properly.

#### *Temporary Seeding and Mulch*

Temporary seeding is an important measure that shall be addressed with all permitted projects: commercial or residential. The Temporary seeding set for within this document shall be followed. Temporary seeding and mulching shall be applied to any areas that have earth changes that have been initiated but will not be completed within 2 weeks or disturbed areas on a site that have been cleared but are not worked for more than a week and falls between the dates of April 1st and October 15th. Mulch shall be applied to any areas that have earth changes that have been initiated but will not be completed within 2 weeks or disturbed areas on a site that have been cleared but are not worked for more than a week and falls between the dates of October 15th and April 1st of the following year. After April 1st of the following year, temporary seed shall be applied.

#### *Permit Life and Closure*

SESC Permits are valid for one year from the date of issuance. Projects not completed with permanent measures installed within that time frame will expire and shall be renewed. All costs associated with renewing an expired permit will be applicable. Earth change areas that fall within the boundaries of future single family home lots, units or parcels shall be stabilized using the specification set forth in this document. Under all other circumstances, the SESC permit will not be closed until all permanent measures have been installed properly and accepted by GCDC-WWS. All project files shall remain open until the site has been stabilized with the exception of site condos, plats or parcelization under the Land Division Act and until such time as the project has been closed out by GCDC-WWS.



JOHN ENGLER  
GOVERNOR

STATE OF MICHIGAN  
DEPARTMENT OF ENVIRONMENTAL C  
LANSING



RUSSELL J. HARDING  
DIRECTOR

April 30, 2002

Mr. Michael J. Carr, Clerk  
Genesee County Board of Commissioners  
900 South Saginaw Street, Room 202  
Flint, Michigan 48502

Dear Mr. Carr:

The Genesee County Soil Erosion and Sedimentation Control (SESC) Resolution adopted on March 12, 2002, has been reviewed by the Land and Water Management Division's (LWMD's) SESC staff. The resolution meets the requirements of Part 91, SESC, of the Natural Resources and Environmental Protection Act, 1994 PA 451, as amended, and is hereby approved. Please note that any policies, procedures, or rules adopted under the authority of this resolution must also be reviewed and approved by the LWMD.

Past and current efforts made by Genesee County to improve and strengthen the County SESC Program are commendable. Updating the resolution, in conjunction with the other SESC Program revisions currently being implemented, should result in more consistent and effective protection of the County and State's natural resources.

If you have any questions, please contact Ms. Lisa Warner, SESC Program, Shiawassee District Office, at 517-625-4612.

Sincerely,

Richard A. Powers, Chief  
Land and Water Management Division  
517-373-1170

cc: Mr. Mark Horgan, Genesee County Drain Commission  
Ms. Lisa Warner, DEQ  
Mr. Dick Mikula, DEQ

CERTIFIED COPY OF RECORD

STATE OF MICHIGAN)  
                          } SS.  
County of Genesee)

I, MICHAEL J. CARR, County Clerk of the County of Genesee, Michigan, and Clerk of the Circuit Court for said County, do hereby certify that I have compared the foregoing copy of Resolution ratifying expedited action of Joint Public Works/Finance Committee taken on February 27, 2002, on behalf of this Board, designating County Drain Commissioner as the County Enforcing Agency for purposes of administering and enforcing Part 91 [MCL 324.9101 et seq] of the Natural Resources and Environmental Protection Act (Soil Erosion and Sedimentation Control) with original record thereof now remaining in my office, and that the attached is a true and correct copy therefrom, and of the whole of such original record.

In Testimony Whereof, I have hereunto set my hand, and affixed the seal of said Court and County, this 18th day of March A.D. 2002.

GENESEEE COUNTY BOARD  
OF COUNTY COMMISSIONERS  
Resolution No.: 02-92  
Date Adopted : March 12, 2002

MICHAEL J. CARR, Clerk

BY: Susan F. DeVerney  
Deputy County Clerk

02-92

TO THE HONORABLE CHAIRPERSON AND MEMBERS OF THE GENESEE  
COUNTY BOARD OF COMMISSIONERS, GENESEE COUNTY, MICHIGAN

LADY AND GENTLEMEN:

WHEREAS, 1994 PA 451, as amended, being MCLA 324.9101 et seq. (hereinafter "Part 91"), was passed by the Michigan Legislature and became immediately effective May 24, 1995; and

WHEREAS, Part 91 was enacted to establish unified soil erosion and sedimentation control programs throughout the State of Michigan; and

WHEREAS, Section 9105 of Part 91 requires that the County Board of Commissioners of each county designate, by resolution, a county agency, or a conservation district upon the concurrence of the conservation district, to be responsible for the administration and enforcement of Part 91, and the rules promulgated under said part, on behalf of the named county.

NOW, THEREFORE, BE IT RESOLVED, that this Board of Commissioners of Genesee County, Michigan hereby ratifies the timely action taken on February 27, 2002, by the Joint Public Works/Finance Committee of this Board, on behalf of this Board, designating the Genesee County Drain Commissioner as the County Enforcing Agency for the purposes of administering and enforcing Part 91 aforesaid, and the rules promulgated thereunder, in Genesee County, Michigan.

BE IT FURTHER RESOLVED, that the County Enforcing Agency be, and hereby is, authorized to establish procedures, policies, rules, and



regulations and fees to administer and enforce the Genesee County Soil Erosion and Sedimentation Control Program.

BE IT FURTHER RESOLVED, that Resolution 73-216, adopted by the Genesee County Board of Commissioners on April 10, 1973, be, and the same hereby is, rescinded.

BE IT FURTHER RESOLVED, that the Clerk of this Board is directed to send a copy of this Resolution to the Michigan Department of Environmental Quality for the Department's review and approval [per MCL 324.9105(4)].

DATE: March 12, 2002

---

Richard E. Hammel  
Chairperson  
Genesee County Board of Commissioners

---

Michael J. Carr  
Genesee County Clerk

JOINT PUBLIC WORKS/FINANCE COMMITTEE

P022702VIA

JGM:saw  
03-04-02

03-02-P2

P2

## **PART 2: SEEDING AND SOIL SUPPLEMENTS**

## **PART 2: SEEDING AND SOIL SUPPLEMENTS**

### **A. QUALITY ASSURANCE**

Provide seed mixture in containers showing percentage of seed mix, germination percentage, inert matter percentage, weed percentage, year of production, net weight, date of packaging, and location of packaging.

### **B. DEFINITIONS & TERMINOLOGY**

Section 9101 of the above-mentioned Act and R323.1701 of the administrative rules have been utilized to define terms used within this document. In addition, the following definitions have been defined by GCDC-WWS:

*Commercial Permit*- All projects where earth changes involve road and/or utility infrastructure, buildings not considered a single-family home, or cutting/filling for improvements on such properties.

*Critical area*- An area that is difficult to stabilize after the existing vegetation has been removed. These areas include such areas as infertile subsoils, droughty soils, areas of concentrated water flow, heavy traffic areas and long or steep slopes.

*Gully erosion* - The formation of deep grooves in the earth's surface as a result of concentrated flow of runoff.

*Non-critical area*- An area that vegetative cover can be re-established easily.

*Residential Permit*- A project where the earth change is located on a single piece of property for the purpose of building or demolishing a single family home. This also includes other improvements, such as ponds, decks, additions, and cutting/filling.

*Rill erosion* - The result of runoff dislodging soil and forming groves into the soil.

*Sensitive area*- An area that is adjacent to Waters of the State.

*Sheet erosion*- The removal of a uniform layer of soil from either rain splash or runoff.

*Turbidity*- Suspended sediment within the water column making the water appear opaque.

*Weeds* - Dandelion, Jimsonweed, Quackgrass, Horsetail, Morning Glory, Rush Grass, Mustard, Lambsquarter, Chickweed, Cress, Crabgrass, Canadian Thistle, Nutgrass, Poison Oak, Blackberry, Tansy Ragwort, Bermuda Grass, Johnson Grass, Poison Ivy, Nut Sedge, Nimble Will, Bindweed, Bent Grass, Wild Garlic, Perennial Sorrel, and Brome Grass.

*Woven Geotextile Filter Fabric* – shall be of a high tensile and puncture strength, with low elongation and can withstand the stresses associated with installation. Permittivity and water flow rate shall be per ASTM D4491.

**C. REGULATORY REQUIREMENTS**

Comply with regulatory agencies for fertilizer and herbicide composition.

Provide certificate of compliance from authority having jurisdiction indicating approval of seed mixture.

**D. DELIVERY, STORAGE, AND HANDLING**

Deliver grass seed mixture in sealed containers. Seed in damaged packaging is not acceptable.

Deliver fertilizer in waterproof bags showing weight, chemical analysis, and name of manufacturer.

Deliver trees, saplings, whips and shrubs in suitable nursery containers, wraps, balls, etc. per Michigan Department of Transportation (MDOT) Landscaping standards and specifications.

**E. SOIL MATERIALS**

1. SUBSOIL

- a. Excavated and re-used material, graded, free of lumps larger than 3-inch (75 mm), rocks larger than 2 inch (50 mm), and debris; conforming to ASTM D2487 Group Symbol CL and OL.
- b. Imported material, graded, free of lumps larger than 3 inch (75 mm), rocks larger than 2 inch (50 mm), and debris; conforming to ASTM D2487 Group Symbol CL and OL.

2. Topsoil

- a. Excavated and reused material, graded, free of roots, rocks larger than ½ inch (12 mm), subsoil debris, large weeds, and foreign matter; conforming to ASTM D2487 Group Symbol OH and PT, in addition this classification shall meet the conditions listed in Topsoil Composition listed below.
- b. Imported friable loam; reasonable free of roots, rocks larger than ½ inch (12 mm), subsoil, debris, large weeds, and foreign matter; acidity range (pH) of 5.5 to 7.5; containing a minimum of 2 percent and a maximum of 25 percent in organic matter; conforming to ASTM D2487 Group Symbol

OH and PT. Limit decaying matter to 10 percent of total content by volume. In addition, this classification shall meet the conditions listed in Topsoil Composition listed below.

- c. Topsoil Composition – shall be screened, fertile, friable, free draining, loam or silt loam soil. It shall be free of subsoil or soils of a mixed textural class and shall not contained rocks or stones larger than ½ inch in diameter. Topsoil shall not contain any impurities such as roots, brush, weeds, slag, cinders, ash, trash, herbicides, or any other substances detrimental to the development of vegetative growth. Topsoil shall be free of contamination by heavy metals including lead and zinc, or any other materials, which may be toxic to seedlings or established grass. Moisture content shall not exceed 6% and topsoil shall conform to the following tables:

Topsoil Guidelines

Soluble Salts (DS/m or mmho/cm)	pH	Sand (%)	Silt (%)	Clay (%)	Texture Class*	Organic Matter (%)	% Coarse fragments (>2 mm in diameter)**	Sodium Adsorption Ratio (SAR)
<2	5.5 to 7.5	<70	<70	<30	L, SiL	≥ 2.0	≤ 2	< 3 for any Texture

\*L = loam; SiL = Silt Loam

\*\*This guideline also includes no fragments larger than ½ inch in diameter.

TOPSOIL NUTRIENTS AND CONDUCTIVITY:

Electrical Conductivity 1:2.5 (w/v) Extract	<1500 us/cm
Nitrogen	>0.2% (w/w)
Extractable Phosphorus	> 45 mg/Kg
Extractable Potassium	> 240 mg/Kg
Extractable Magnesium	> 80 mg/Kg

**F. TESTS**

Whether topsoil is from on-site or from a third party, Contractor will be required to submit a minimum 10 oz sample of proposed topsoil to an approved testing laboratory. Sample shall be in sealed containers to prevent contamination. The results shall be submitted to GCDC-WWS for review.

Analysis should ascertain percentage of nitrogen, phosphorus, potash, soluble salt content, organic matter content, and pH value.

Contractor to provide a recommendation for fertilizer and lime application rates for specified seed mix as result of testing.

## **G. EXAMINATION**

Verify that prepared soil base is ready to receive all proposed work as defined by the scope of the SESC permit.

## **H. PREPARATION OF SUBSOIL**

Prepare sub-soil to eliminate uneven areas and low spots. Maintain lines, levels, profiles and contours. Make changes in grade gradual. Blend slopes into level areas with a mechanism like a Harley Rake.

Remove foreign materials, weeds and undesirable plants and their roots. Remove contaminated sub-soil.

Scarify subsoil to a depth of 6 inches where topsoil is to be placed. Repeat cultivation in areas where equipment, used for hauling and spreading topsoil, has compacted sub-soil.

## **I. PLACING TOPSOIL**

1. Strip for reuse all native organic soil, topsoil and place in a stockpile at a location acceptable as shown on the approved plan(s) for later use. Do not remove topsoil from the property where it originated unless specifically stated in the SESC Permit and/or Contract Document(s). Take care to prevent contamination of native organic material or topsoil with underlying materials. If the native organic material or topsoil is contaminated, it shall not be accepted and additional imported topsoil, acceptable to the Engineer and Owner, shall be required to be supplied at no additional cost to the project.
2. Spread topsoil to a depth of 3 to 4 inches over area to be seeded. Prepare until smooth.
3. Place topsoil during dry weather and on dry unfrozen subgrade.
4. Remove vegetative matter, foreign non-organic material, stems larger than ½ inch in diameter, rocks and litter from topsoil while spreading.
5. Provide friable topsoil surface that is reasonably close to proposal grades and cross-section.
6. Grade topsoil to eliminate rough, low or soft areas, and to ensure positive drainage.
7. Install edging at periphery of seeded areas in straight lines to consistent depth.

## **J. FERTILIZING**

1. In areas to be seeded, at least forty-eight (48) hours before the placing of any seed, commercial fertilizer shall be uniformly spread over the topsoil at the rate of 240

pounds per acre by a mechanical spreader and mixed into the soil for a depth of two (2) inches. The fertilizer shall then be lightly raked until the surface of the finished grade is smooth, loose, and pulverized.

2. Provide a ready mixed granular chemical fertilizer containing equal amounts by weight of available Nitrogen (N), ready available Phosphoric Acid (P205), and total available Potash (K20) with not less than the 40% by weight of filler or based on the recommendation outlined in section F.
3. Apply after smooth raking of topsoil and prior to compaction. Provide fertilizer in suitable hays, with the net weights of the contents and guaranteed analysis shown therein, or in bulk with certification of the fertilizer analysis and net weight of the shipment.
4. Do not apply fertilizer at same time or with same machine used to apply seed.
5. Mix thoroughly into upper 2 inches of topsoil.
6. Lightly water to aid the dissipation of fertilizer. Irrigate top level of soil uniformly.

**K. SEEDING MIXTURES, RATES, AND DATES**

**1. Permanent Mixtures & Rates (Preferred)**

A. Provide seed mixtures composed of certified seed of the purity, germination and proportions by weight as specified in the following table:

<u>Seeds</u>	<u>Min. Purity</u>	<u>Min. Germination</u>	<u>Mixture</u>	
			1	2
Kentucky Blue Grass:	98%	85%	30%	10%
Creeping Red Fescue:	97%	85%	50%	40%
Perennial Rye:	96%	85%	20%	20%
Hard Fescue	97%	85%		30%

Mixture 1 shall be used for all established lawns, and all mowed areas including ditches. Shall be sown at a rate of 120 lbs per acre.

Mixture 2 shall be used for all slopes, ditches, shoulder and road right of way adjacent to farmed fields. Shall be sown at a rate of 100 lbs per acre.

- B. Do not seed areas in excess of that which can be mulched on same day.
- C. Furnish seeds in double bags with each bag tagged with the supplier, lot number, net weight, purity, germination and mixture proportions.
- D. Do not sow immediately following rain, when ground is too dry, or during windy periods, or when winds are over 12 mph.

- E. Immediately following seeding and compacting, apply mulch to a thickness of 1/4 inch. Maintain clear of shrubs and trees.
- F. Protect signs, traffic, entrances, and other objects from being marked or disfigured by mulch adhesives, if used.
- G. Apply asphalt emulsion adhesives at a rate of 150 gallons per acre; apply latex based adhesives at a rate of 400 gallons per acre.
- H. Apply water with a fine spray immediately after each area has been mulched. Saturate to a depth of 6 inches of soil.
- I. Spread mulch net over the mulch layer and secured with staples driven into the ground, if used. The net shall not be held in contact with the ground.
- J. Grass seed shall be sown by a mechanical seeder, operating in two directions, and lightly raked into the surface and rolled once with a light hand roller. The seeded areas shall be thoroughly watered with a fine spray in such a manner as not to wash out the seed. The Contractor shall use care in raking, not to destroy the finished grade, nor to disturb uniform distribution of seed. Times of year for sowing of seeds shall be consistent with standard practice subject to approval by GCDC-WWS.
- K. Provide seed mixtures that meet purity and germination requirements as specified in the Proceedings of the Association of Official Seed Analysis, Rules for Testing Seeds.
- L. The areas that have been seeded shall be watered, maintained and patched as necessary by the Contractor until the seed is fully established and actively growing and free of weeds. It is the Contractor's responsibility to provide all required watering until the new seeding is fully established.

**2. Permanent Seeding Dates**

<b>Spring Seeding Dates</b>	See note below regarding summer seeding	<b>Fall Seeding Dates</b>
April 1 – May 20		August 10 – October 1

Summer Seeding is reliable only if irrigation is available. If a project is completed in the summer and irrigation is not available, it is usually not feasible or advisable to delay seeding. Ensure that summer seeding is accompanied by an adequate thickness of properly anchored mulch. Even with the greatest care, follow up maintenance of summer seeding is more likely than for spring or fall seeding.



### 3. Temporary Seeding Rates and Dates

Common Name	Seeding Rates		Seeding Dates
	Rates/Acre	Rate/1000 sq. ft.	
Oats	3 bushels	2 pounds	4/1 to 9/15
Barley	3 bushels	2 pounds	4/1 to 9/15
Annual Ryegrass	25 pounds	¾ pounds	4/1 to 9/15
Sudangrass	35 pounds	1 pounds	6/1 to 7/15
Winter Wheat	2 bushels	1.5 pounds	9/20 to 10/15
Cereal Rye	2 bushels	1.5 pounds	8/1 to 10/15

Cereal rye and winter wheat will be destroyed by seedbed preparation at the next permanent seeding period. Cereal rye may inhibit the growth of other species.

### L. ACCESSORIES

1. Mulching.
  - a. Material: Hay, straw, march hay or wood cellulose fiber.
  - b. Net: Biodegradable wash with openings not to exceed 1½"x3".
  - c. Net Width: Not less than 35 inches.
  - d. Net Staples: At least six inches long and made from No. 11 wire.
2. Water.
  - a. Clean, fresh and free of substances or matter capable of inhibiting vigorous growth of grass.
3. Erosion Fabric.
  - a. High velocity straw mat meeting the current Michigan Department of Transportation requirements, or if approved by the Owner, open weave jute matting.
4. Stakes.
  - a. Softwood lumber, chisel pointed.
5. String.
  - a. Inorganic fiber.

**M. HYDROSEEDING**

1. Apply seed, fertilizer, and mulch in slurry with a hydraulic seeder evenly in two intersecting directions.
2. Add wood cellulose mulch materials after the seed and fertilizer have been thoroughly mixed.
3. Do not hydroseed area in excess of that which can be mulched on same day.
4. Constantly agitate mixtures and apply within eight hours of mixing.
5. Hydroseed mixtures not containing mulch:
  - a. Immediately following seeding, apply mulch to a thickness of 1/4 inch. Maintain clear of shrubs and trees.
  - b. Apply water with a fine spray immediately after each area has been mulched. Saturate to 6 inches of soil.
6. Hydro-seed with a pump rated and operated at no less than 100 GPM and no less than 100 PSI, with a mechanical agitator that will insure uniform suspension of seed, fertilizer and mulch in water. Each 1,000 gallons of slurry mix shall contain 1,500 lbs of approved cellulose fiber, 200 pounds of the specified seed mixture and 500 pounds of an approved commercial fertilizer. Apply seed, fertilizer and mulch at a rate of not less than 1,000 gallons of slurry per acre.
7. Seed shall meet the requirements for purity and germination as specified in the Proceedings of the Association of Official Seed Analysis, Rules for Testing Seeds. Deficiencies below the percentage specified for purity and germination will be evaluated for acceptability by GCDC-WWS. Furnish seeds in double bags with each bag tagged with the supplier, lot number, net weight, purity and germination.
8. The seeding mixture shall be composed of certified seed of the purity, germination, and proportions, by weight, as specified in the following table:

<u>Seeds</u>	<u>Min. Purity</u>	<u>Min. Germination</u>	<u>Mixture Proportion</u>
Kentucky Blue Grass:	98%	85%	30%
Creeping Red Fescue:	97%	85%	50%
Perennial Rye:	96%	85%	20%

9. Mulch shall be incorporated into the fertilizer-seed slurry unless otherwise specified. Subject to the approval of the Owner, the mulch shall be held in place by a spray coating of adhesive material. Mulch adhesive shall be applied by spraying simultaneously with the seed-fertilizer-mulch slurry.
10. Hydroseeding allowed only in areas that can be artificially irrigated.

**N. SOD**

1. For all lawn areas that were originally established by sodding, the Contractor shall be required to replace excavated areas with sod. The sodding area shall be prepared as for seeding. The sod shall be a densely rooted blend of at least two blue grass varieties with 15 percent to 30 percent creeping red fescue content, and reasonably free from weeds. The Contractor shall water and maintain the sodded areas until they are established.

**O. SEED PROTECTION**

1. Identify seeded areas with stakes and string around area periphery.
2. Cover seeded slopes with anchored woven fabric where grade is 4 inch per foot or greater and stream banks, unless directed otherwise on the approved SESC plan sheets. Woven fabric shall not be stretched or pulled while installing.
3. Lay fabric smoothly on surface perpendicular to slope, bury top end of each section in 6 inch deep excavated topsoil trench. Overlap of adjacent rolls. Backfill trench and rake smooth -- level with adjacent soil.
4. Secure outside edges and overlaps at 36 inch intervals with stakes.
5. Lightly dress slopes with topsoil to ensure close contact between fabric and soil.
6. At sides of ditches, lay fabric laps in direction of water flow. Lap ends and edges minimum 6 inch.
7. Perform permanent seeding between May 1 and June 15 or between August 15 and October 10, unless otherwise approved by the GCDC-WWS.
8. During other periods stabilize disturbed areas by temporary cereal rye seeding.

**P. MAINTENANCE**

1. Provide a minimum of one mowing and additional mowing as needed to keep the construction area presentable prior to final acceptance, as determined by the Owner. Mow grass at regular intervals to maintain at a maximum height of 2-1/2 inch. Do not cut more than 1/3 of grass blade at any one mowing. Perform first mowing when seedlings are 40 percent higher than desired height.
2. Neatly trim edges and hand clip where necessary.
3. Immediately remove clippings after mowing and trimming. Do not let clippings lay in clumps

4. Water to prevent grass and soil from drying out.
5. Control growth of weeds. Apply herbicides in accordance with manufacturer's instructions. Remedy damage resulting from improper use of herbicides.
6. Immediately reseed areas which show bare spots.
7. Protect seeded areas with warning signs during maintenance period.
8. Repair rills, washouts or gullies via means and methods chosen by the Contractor.
9. Maintain seeded areas immediately after placement for at least one year and until grass is well established and exhibits a vigorous growing condition.
10. Maintain individual trees and shrubs that are supplied and planted or relocated, excluding wetland whips or saplings, for a minimum of one year until they are established and exhibit vigorous growth.

**PART 3: MICHIGAN UNIFIED KEYING SYSTEM**



## **PART 4: DETAILS**

## NO DRAWING DETAIL PROVIDED

### APPLICATIONS

1. ON CONSTRUCTION SITES DURING PERIODS OF LOW PRECIPITATION, LOW HUMIDITY AND HIGH TEMPERATURE OR HIGH WINDS.
2. USE ON UNPAVED ROADWAYS, CONSTRUCTION SITES WITH VEHICLE TRAFFIC, SOIL STOCKPILE AREAS AND GENERAL AREAS WITH UNSTABILIZED OR FINE SOILS.

### DESIGN

1. DUST CONTROL APPLICATIONS CAN INCLUDE WATERING, CHEMICAL DUST SUPPRESSION, GRAVEL OR ASPHALT SURFACING, TEMPORARY AGGREGATE COVER AND HAUL TRUCK COVERS.
2. FOLLOW MANUFACTURER'S INSTRUCTIONS REGARDING APPLICATION OF ANY DUST PALLIATIVE AND MIXING DETAILS.
3. APPLY DUST SUPPRESSANT TO SURFACES USING A PRESSURE TYPE WATER DISTRIBUTOR TRUCK EQUIPPED WITH A SPRAY SYSTEM.
4. LIMIT VEHICULAR TRAFFIC TO 15 MILES PER HOUR.
5. IMMEDIATELY CLEAN-UP SEDIMENT TRACKED ONTO PAVED ROADS. KEEP CONSTRUCTION TRAFFIC DIRECTED TO STABILIZED SITE ROADWAYS WHEN POSSIBLE.
6. DUST CONTROL APPLICATION NEEDS TO BE APPLIED ON A REGULAR SCHEDULE TO MAINTAIN EFFECTIVENESS.



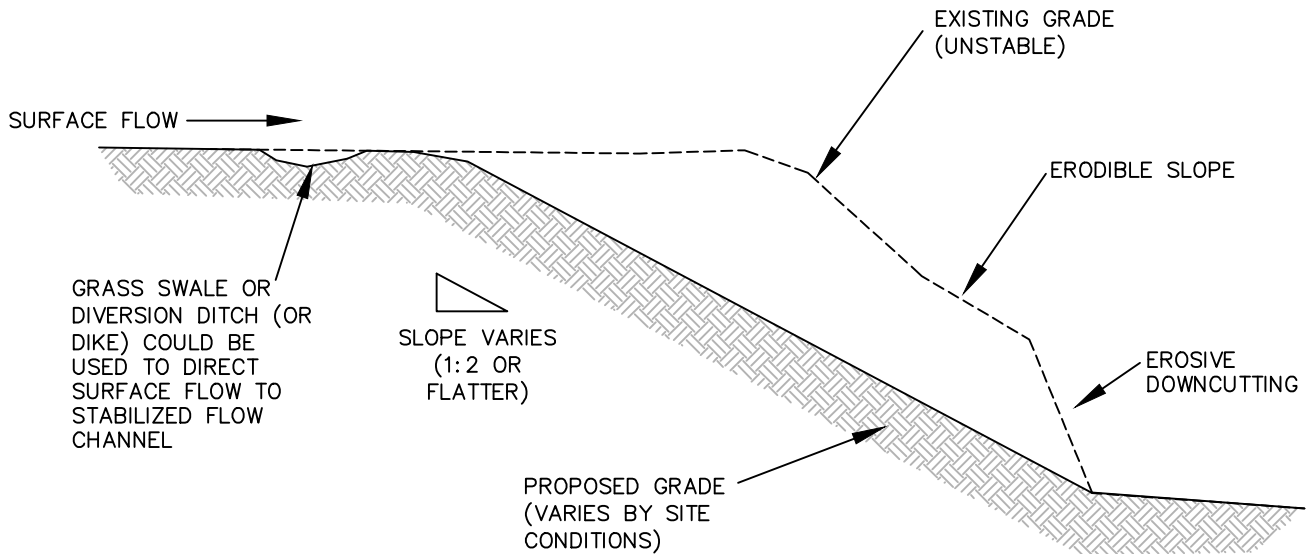

NOTE: PROPOSED GRADE DEPENDENT ON SITE SPECIFIC CHARACTERISTICS SUCH AS SOIL TYPE, VEGETATIVE COVER, AND WATER MOVEMENT ABOVE AND BELOW GRADE.

#### APPLICATIONS

1. WHENEVER EXISTING SLOPES OR CONSTRUCTION ACTIVITIES RESULT IN GRADES WHICH MAY BE SUBJECT TO EROSION VELOCITIES CAPABLE OF DOWNCUTTING OR EROSION RESULTING IN OFF-SITE SEDIMENTATION.
2. WHERE EXISTING NATURAL OR CREATED GRADES ARE SUBJECT TO SURFACE FLOWS CAPABLE OF CREATING GULLIES, RILLS, OR OTHER SURFACE EROSION PROBLEMS.

#### DESIGN

1. ESTABLISH SLOPES APPROPRIATE FOR INTENDED USE. SLOPES, IN GENERAL, SHOULD BE FLATTER THAN 1:2. SLOPES REQUIRING MOWING SHOULD BE NO STEEPER THAN 1:3.
2. AVOID SENSITIVE AREAS (WATERCOURSES, WETLANDS, VEGETATIVE BUFFERS) WITH GRADING/SHAPING.
3. DIVERT SURFACE FLOWS TO AREAS APPROPRIATELY STABILIZED TO HANDLE EXPECTED VOLUMES AND VELOCITIES.
4. LOCATE SPOIL AREAS AWAY FROM SENSITIVE AREAS OR FLOW PATHS AND STABILIZE WITH SEED.
5. EXPOSED AREAS SHOULD BE STABILIZED WITH VEGETATION OR OTHER GROUND COVER AS SOON AS WORK IS COMPLETED OR INTERRUPTED FOR 2 NORMAL WORK WEEKS.

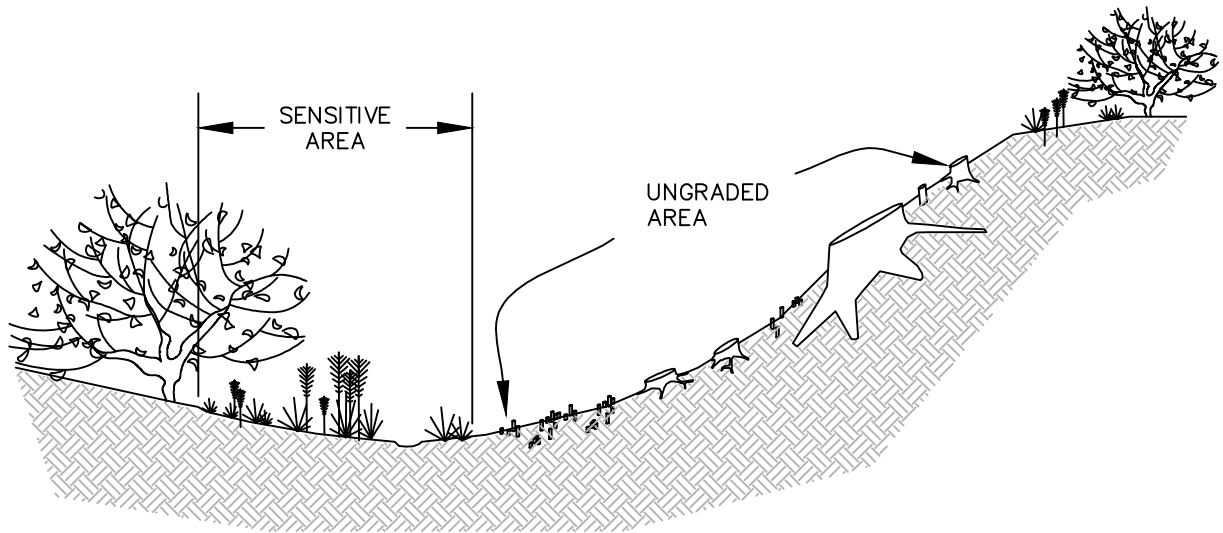

### APPLICATIONS

1. WHEN RETAINING VEGETATIVE ROOT MASSES CAN ALLOW VISUAL ACCESS OR AID IN SLOPE STABILIZATION.
2. FOR USE ON SLOPES WHERE BRIDGE SPANS AND BOARDWALK CONSTRUCTION IS PROPOSED OR WHERE CLEAR VISION CORRIDORS ARE NECESSARY.

### DESIGN

1. IDENTIFY AREAS WHERE GRUBBING IS NOT NECESSARY.
2. CUT VEGETATION WITHIN A FEW INCHES OF NATURAL GROUND SURFACE.
3. LEAVE ROOT ZONE INTACT. DO NOT GRADE AREA.

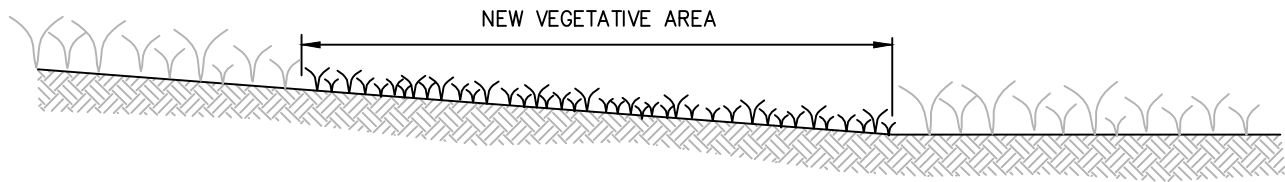

## TEMPORARY SEEDING

### APPLICATIONS

1. WHEN AN AREA NEEDS STABILIZATION DURING A BREAK IN CONSTRUCTION.
2. TO STABILIZE SOIL AND PREVENT OR REDUCE SOIL EROSION/SEDIMENTATION PROBLEMS FROM DEVELOPING.
3. USED ON CONSTRUCTION AND EARTH CHANGE SITES WHICH REQUIRE TEMPORARY VEGETATIVE STABILIZATION.

### DESIGN

1. REVIEW SESC PLAN AND CONSTRUCTION PHASING TO IDENTIFY AREAS IN NEED OF TEMPORARY VEGETATIVE STABILIZATION.
2. SELECT ANNUAL GRASS SEED FOR TEMPORARY COVER AREAS.
3. SEED MIXES MAY VARY, SHOULD ONLY CONTAIN ANNUAL, NON-AGGRESSIVE SPECIES, AND GENERALLY INCLUDE RYE, WHEAT OR OAT SPECIES. SEED MIXES SHOULD OBTAINED THROUGH CONSULTATION WITH A CERTIFIED SEED PROVIDER AND WITH CONSIDERATION OF SOIL TYPE, LIGHT, MOISTURE AND USE APPLICATION.
4. PREPARE SEEDBED BY REMOVAL OF CONSTRUCTION AND WOODY DEBRIS. THEN SCARIFY OR RAKE SEEDBED.
5. SLOPES STEEPER THAN 1:3 SHOULD BE ROUGHENED.
6. APPLY SEED AS SOON AS POSSIBLE AFTER SEEDBED PREPARATION. MULCH IMMEDIATELY AFTER SEEDING ALL SLOPES, UNSTABLE SOILS, HEAVY CLAY SOILS AND ALL AREAS ADJACENT TO WETLANDS, WATERCOURSES, OR SENSITIVE AREAS.
7. PROTECT SEEDED AREAS FROM PEDESTRIAN OR VEHICULAR TRAFFIC.
8. DIVERT CONCENTRATED FLOWS AWAY FROM THE SEEDED AREA UNTIL VEGETATION IS ESTABLISHED.
9. INSPECT TEMPORARY SEEDED AREAS WEEKLY AND FOLLOWING EACH RAIN EVENT UNTIL FINAL GRADING AND STABILIZATION ARE COMPLETED.
10. TEMPORARY SEEDING MUST BE FOLLOWED BY PERMANENT SEEDING.

## PERMANENT SEEDING

### APPLICATIONS

1. TO FINALIZE STABILIZATION OF TEMPORARY SEEDING AREAS OR WHEN AN AREA NEEDS PERMANENT STABILIZATION FOLLOWING COMPLETION OF CONSTRUCTION. ALSO USED WHEN VEGETATIVE ESTABLISHMENT CAN CORRECT EXISTING SOIL EROSION OR SEDIMENTATION PROBLEM.
2. TO STABILIZE SOIL AND PREVENT OR REDUCE SOIL EROSION/SEDIMENTATION PROBLEMS FROM DEVELOPING.
3. USED ON CONSTRUCTION AND EARTH CHANGE SITES WHICH REQUIRE PERMANENT VEGETATIVE STABILIZATION.

### DESIGN

1. REVIEW SESC PLAN AND CONSTRUCTION PHASING TO IDENTIFY AREAS IN NEED OF PERMANENT VEGETATIVE STABILIZATION.
2. SELECT PERENNIAL GRASS AND GROUND COVER FOR PERMANENT COVER.
3. SEED MIXES MAY VARY BUT SHOULD BE SELECTED THROUGH CONSULTATION WITH A CERTIFIED SEED PROVIDER AND WITH CONSIDERATION OF SOIL TYPE, LIGHT, MOISTURE, USE APPLICATIONS, AND NATIVE SPECIES CONTENT.
4. SOIL TESTS SHOULD BE PERFORMED TO DETERMINE THE NUTRIENT AND PH LEVELS IN THE SOIL. THE PH MAY NEED TO BE ADJUSTED TO BETWEEN 6.5 AND 7.0.
5. PREPARE A 3-5" DEEP SEEDBED, WITH THE TOP 3-4" CONSISTING OF TOPSOIL.
6. SLOPES STEEPER THAN 1:3 SHOULD BE ROUGHENED.
7. APPLY SEED AS SOON AS POSSIBLE AFTER SEEDBED PREPARATION. SEED MAY BE BROADCAST BY HAND, HYDROSEEDING, OR BY USING MECHANICAL DRILLS.
8. DORMANT SEED MIXES ARE FOR USE AFTER THE GROWING SEASON, USING SEED WHICH LIES DORMANT IN THE WINTER AND BEGINS GROWING AS SOON AS SITE CONDITIONS BECOME FAVORABLE.
9. MULCH IMMEDIATELY AFTER SEEDING.
10. PROTECT SEEDED AREAS FROM PEDESTRIAN OR VEHICULAR TRAFFIC.
11. DIVERT CONCENTRATED FLOWS AWAY FROM THE SEEDED AREA UNTIL VEGETATION IS ESTABLISHED.

THIS PAGE INTENTIONALLY LEFT BLANK

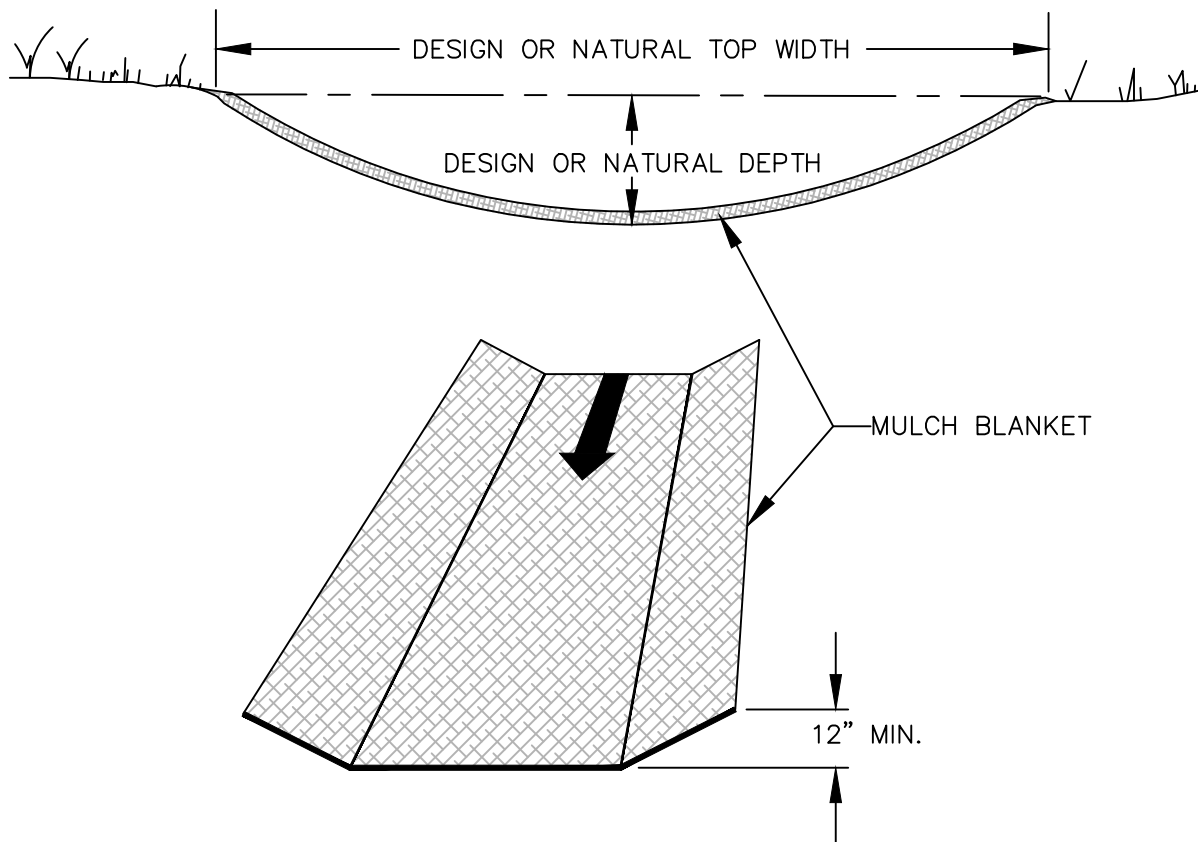

### APPLICATIONS

1. STEEP SLOPES.
2. CHANNEL AND ROADSIDE DITCH BOTTOMS.
3. USE SEED AND HIGH VELOCITY MULCH BLANKETS TO STABILIZE THE GRASSED LINED CHANNEL, IMMEDIATELY AFTER GRADING (ONE DAY MAX).
4. MUST NOT BE PLACED ON FROZEN SOIL: MUST REMAIN IN CONTACT WITH SEED AND SOIL.
5. MUST BE USED DURING THE NON-GROWING SEASON TO MINIMIZE EROSION UNTIL VEGETATION IS ESTABLISHED.

### DESIGN

1. FOR DITCHES AND CHANNELS ROLL HIGH VELOCITY MULCH BLANKETS IN THE DIRECTION OF FLOW. DO NOT STRETCH.
2. FASTEN OR PEG MULCH BLANKET PER MANUFACTURERS INSTRUCTIONS.
3. ON BACKSLOPES, BLANKETS SHALL BE PLACED AT RIGHT ANGLES TO ROADBED OR PIPE LINE.
4. OVERLAY ENDS BY 18" AND EDGES BY 4".
5. AT ALL BLANKET EDGES, BURY 6'-10" OF BLANKET IN 3-4' DEEP TRENCH AND COMPACT TRENCH WITH NATIVE SOIL BACKFILL OR MDOT 6AA STONE.

THIS PAGE INTENTIONALLY LEFT BLANK

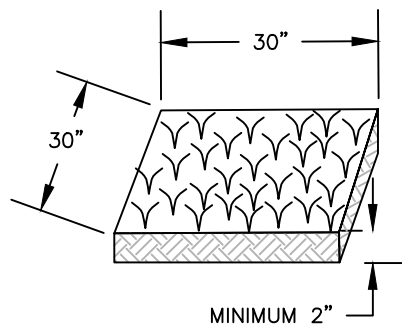

INDIVIDUAL SOD SECTION

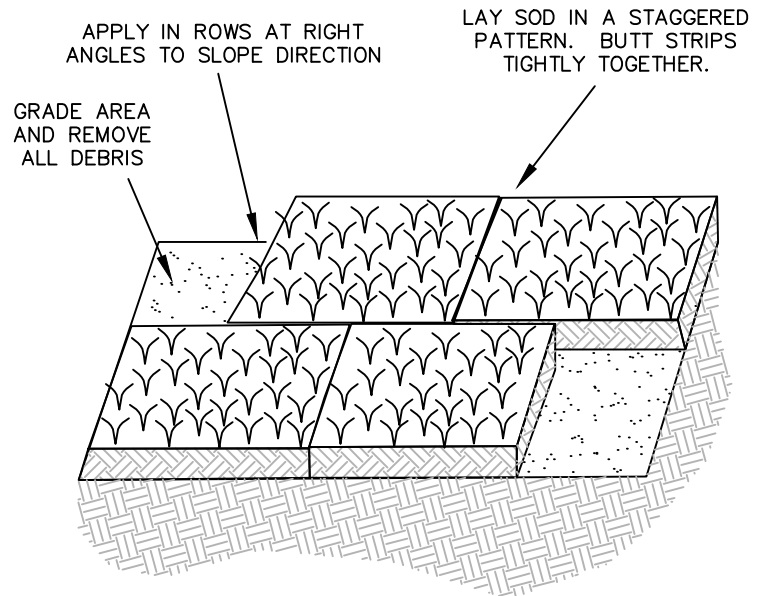

## APPLICATIONS

1. WHEN IMMEDIATE VEGETATIVE COVER IS NEEDED ON EXPOSED AREAS.
2. APPLY ON EXPOSED AREAS/SLOPES WHERE VEGETATIVE STABILIZATION IS NEEDED SOONER THAN CAN BE ESTABLISHED BY SEEDING AND WHERE IRRIGATION IS AVAILABLE.

## DESIGN

1. PREPARE AREA BY GRADING AND REMOVAL OF STICKS, ROCKS, ROOTS, SOIL CLODS, AND CONSTRUCTION DEBRIS.
2. COMPLETE SOIL TESTING TO DETERMINE PH AND NUTRIENT CONTENT OF SOIL.
3. APPLY SOIL AMENDMENTS AS NECESSARY PER SOIL TESTING.
4. SELECT SOD TYPE BASED ON EXPECTED EXPOSURE AND MOISTURE REGIMES, PLANNED MAINTENANCE LEVEL, AND INTENDED USE.
5. STRIPS OF SOD SHOULD BE UNIFORM IN WIDTH WITH STRIPS FREE OF WEEDS.
6. CULTURED SOD SHOULD BE APPROXIMATELY 0.5" THICK AND NOT LESS THAN 30" IN LENGTH. OTHER GRASS SODS SHOULD BE CUT AT LEAST 2" THICK AND IN STRIPS AT LEAST 10" BY 18".

## DESIGN (CONT)

7. APPLY SOD IN ROWS PERPENDICULAR TO SLOPE DIRECTION.
8. APPLY SOD PERPENDICULAR TO WATERFLOW DIRECTION ON SLOPES OR IN FLOW PATHS.
9. PLACE SOD PIECES IMMEDIATELY ADJACENT TO ONE ANOTHER WITH NO OPEN JOINTS LEFT BETWEEN STRIP EDGES OR ENDS.
10. STAGGER ENDS OF ADJACENT SOD STRIPS TO MINIMIZE CONCENTRATED FLOW AT JOINTS.
11. ROLL OR TAMP SOD IMMEDIATELY AFTER INSTALLATION.
12. ON SLOPES STEEPER THAN 1:3, OR IN AREAS OF CONCENTRATED FLOWS, SECURE SOD WITH 10" WOOD STAKES OR PEGS SPACED 2 FEET APART, DRIVEN FLUSH WITH THE SOD SURFACE.
13. WATER SOD TO THOROUGHLY MOISTEN SOIL.
14. WITHHOLD TRAFFIC FROM RECENTLY SODDED AREA UNTIL SOD IS FIRMLY ESTABLISHED.
15. SOD CAN BE LAID BETWEEN MAY 1 AND OCTOBER 20. BETWEEN JUNE 10 AND SEPTEMBER 10 IRRIGATION IS NECESSARY.

THE GRAPH SHOWN BELOW IS USED TO DETERMINE THE ADEQUACY OF AN EXISTING VEGETATIVE BUFFER ZONE FOR USE AS A SEDIMENT FILTER. THIS GRAPH IS ONLY APPLICABLE IF THE VEGETATION IS A DENSE WELL-GROWN STAND OF GROUND COVER, AT LEAST 4" IN LENGTH. AN AREA COVERED WITH BUSHES AND TREES WITHOUT A GOOD GROUND COVER IS NOT ACCEPTABLE.

### EXAMPLE

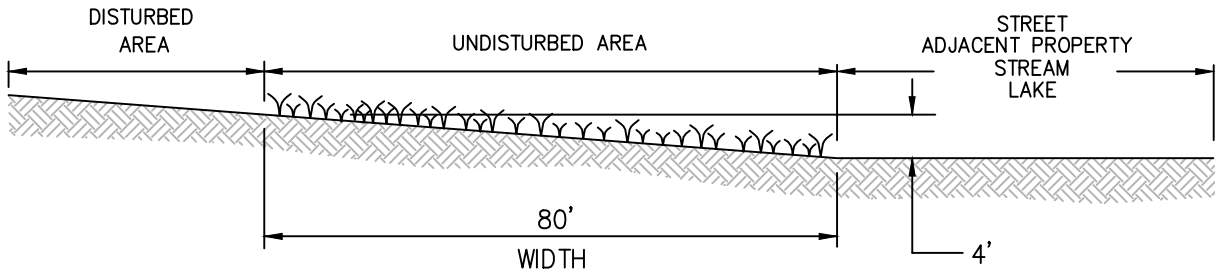

WIDTH OF BUFFER ZONE = 80'  
 DROP OF BUFFER ZONE = 4'  
 % OF SLOPE OF BUFFER ZONE =  $4' / 80' \times 100\% = 5\%$

PLOT ON GRAPH BELOW: BUFFER ZONE IS ACCEPTABLE

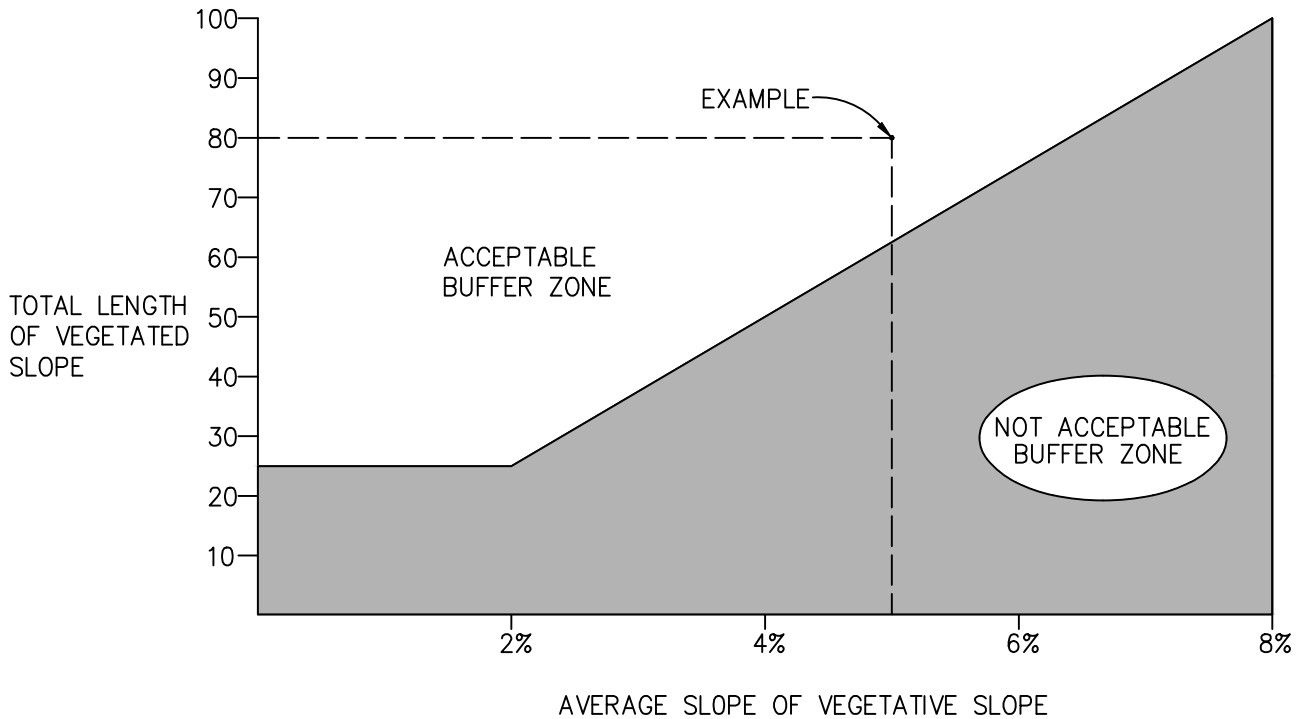



## NO DRAWING DETAIL PROVIDED

### APPLICATIONS

1. WHEN AREAS ARE SUBJECT TO EROSION FROM SHEET FLOWS OR SEVERE WIND.
2. TEMPORARILY PROTECTS SEEDED AREAS AND SLOPES AGAINST EROSION FROM RAIN OR WIND. HOLDS SOIL MOISTURE TO ALLOW FOR SEED GERMINATION AND REDUCES WIND DESSICATION OF GERMINATED SEEDS. INHIBITS SEED CONSUMPTION BY BIRDS.
3. USE ON EXPOSED SLOPES, NEWLY SEEDED AREAS AND OTHER AREAS SUBJECT TO EROSION.

### DESIGN

1. OTHER SURFACE RUNOFF CONTROL MEASURES SHOULD BE INSTALLED PRIOR TO MULCHING.
2. PREPARE SURFACE TO PROPER GRADE AND COMPACTION REQUIREMENTS.
3. IF TREATMENT AREA IS TO BE REVEGETATED IMMEDIATELY, SPREAD OR DRILL SEED, OR INSTALL VEGETATIVE SPRIGS INTO PLANTING SURFACE.
4. SELECT MULCH MATERIAL APPROPRIATE FOR SITE CHARACTERISTICS, INCLUDING GRADE, LEVEL OF TRAFFIC, INSTALLATION METHOD, AND ACCESSIBILITY.

STRAW – MOST COMMON AND WIDELY USED MATERIAL. PROVIDES ORGANIC MATTER AS IT BREAKS DOWN. EFFECTIVENESS OF SEDIMENT REDUCTION HIGH FOR AT LEAST 3 MONTHS. SUBJECT TO WINDBLOW AND WASHOUT. FOR STRAW, APPLY A MINIMUM OF 2 TONS/ACRE OR APPROX. 50 LBS./1000 SQ.FT. TO COVER THE SURFACE. INCREASE APPLICATION RATES 50% FOR DORMANT SEEDING.

### DESIGN (CONT.)

5. MULCHES SHOULD NOT BE APPLIED IF FREE SURFACE WATER IS PRESENT BUT MAY BE APPLIED TO WET SOIL.
6. MULCHES (PARTICULARLY STRAW) MAY NEED ANCHORING. COMMON METHODS INCLUDE CRIMPING, DISKING, OR PUNCHING INTO SOIL; COVERING WITH NETTING; SPRAYING WITH A BINDER/TACKIFIER, OR KEEPING MOIST.
7. IF USING A TACKIFIER TO ANCHOR MULCH IN PLACE, APPLY IMMEDIATELY AFTER MULCH HAS BEEN PLACED. TACKIFIERS INCLUDE:

LATEX-BASE. MIX 37 GALLONS OF ADHESIVE OR THE MANUFACTURER'S RECOMMENDED RATE WITH A MINIMUM OF 620 LBS. OF RECYCLED NEWSPRINT AS A TRACER WITH 925 GALLONS OF WATER.

RECYCLED NEWSPRINT. MIX 1850 LBS. OF NEWSPRINT WITH 3700 GALLONS OF WATER.

WOOD FIBER. MIX 1850 LBS. OF WOOD FIBER WITH 3700 GALLONS OF WATER.

GUAR GUM. MIX 120 LBS. OF DRY ADHESIVE AND A MINIMUM OF 620 LBS. RECYCLED NEWSPRINT AS A TRACER WITH 3225 GALLONS OF WATER.

OTHER TACKIFIERS. MIX 240 LBS. OF DRY ADHESIVE OR THE MANUFACTURER'S RECOMMENDED RATE AND A MINIMUM OF 620 LBS. OF RECYCLED NEWSPRINT AS A TRACER WITH 3225 GALLONS OF WATER.

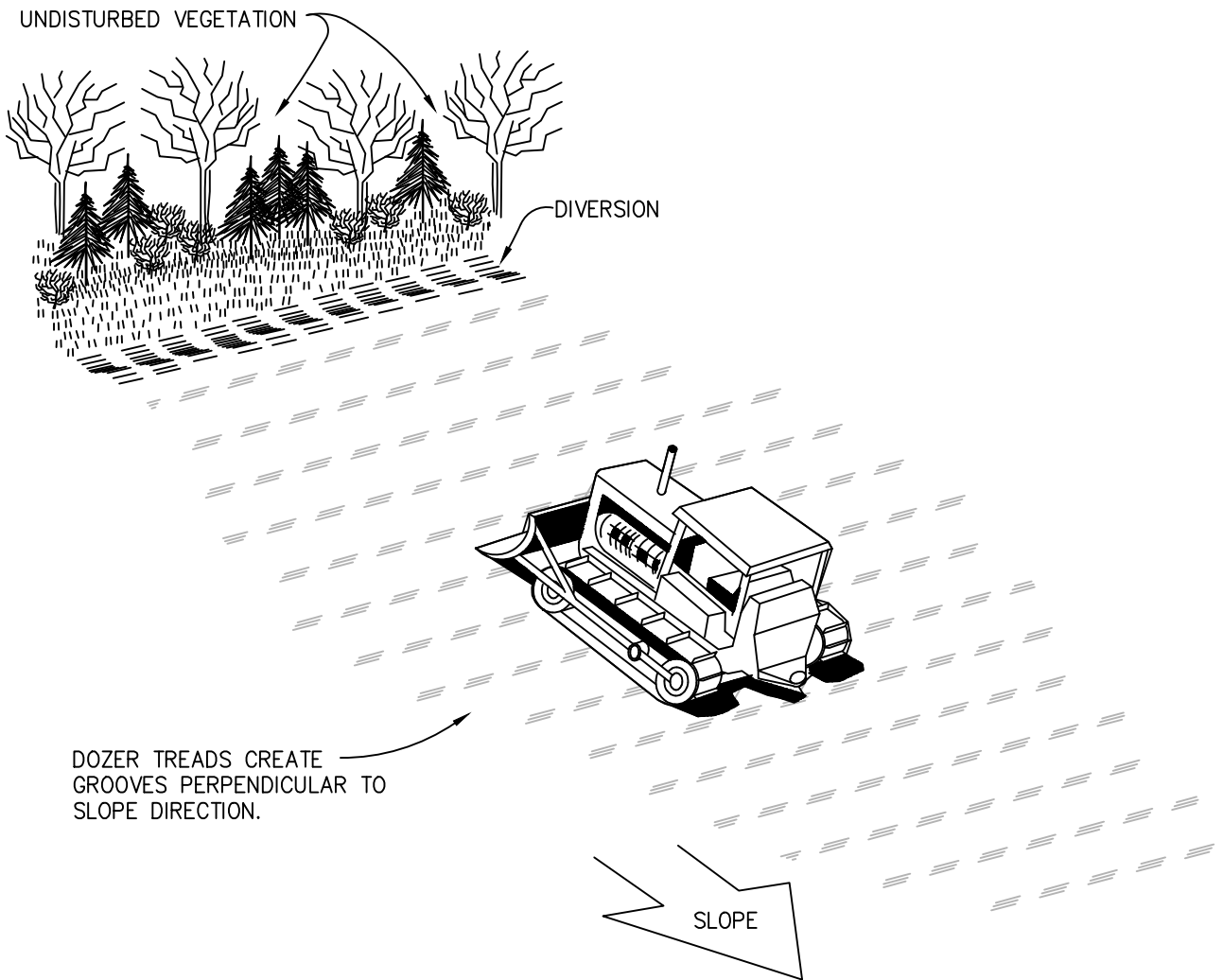

UNVEGETATED SLOPE SHOULD BE TEMPORARILY SCARIFIED TO MINIMIZE RUNOFF VELOCITIES

APPLICATION

PLACE HORIZONTAL GROOVES IN A SLOPE PERPENDICULAR TO THE FLOW OF THE RUNOFF. THIS CAN BE DONE BY EITHER DISC HARROWING, BACK BLADING OR JUST RUNNING THE TREADS OF A CRAWLER TRACTOR PERPENDICULAR TO THE SLOPE AS SHOWN BELOW.

THIS PAGE INTENTIONALLY LEFT BLANK

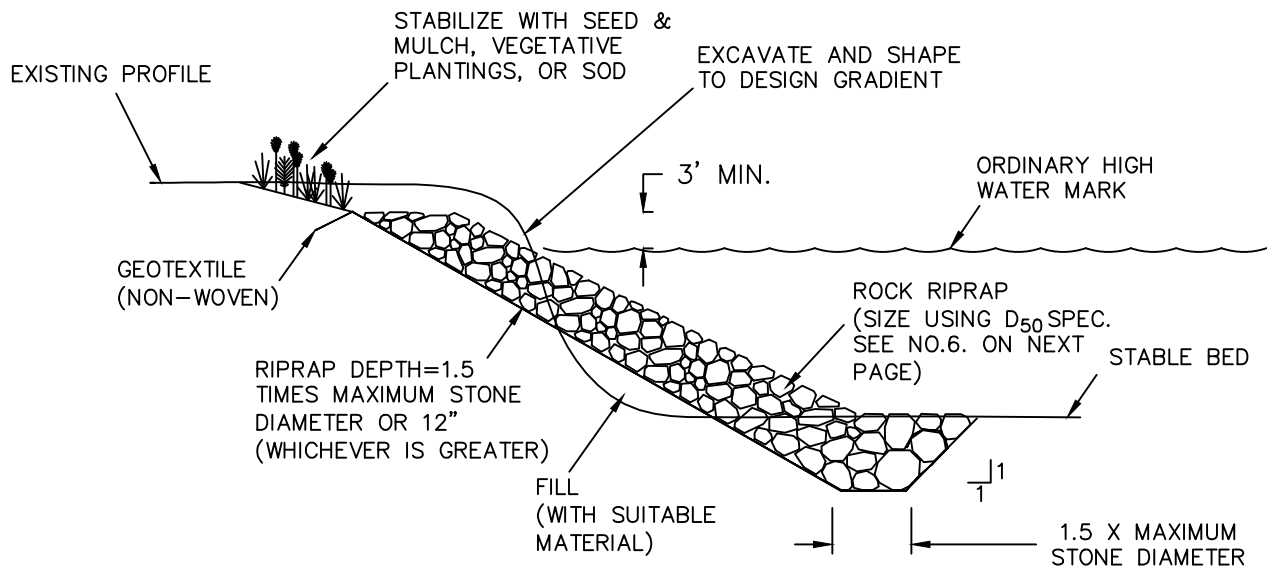

STREAM BANK APPLICATION

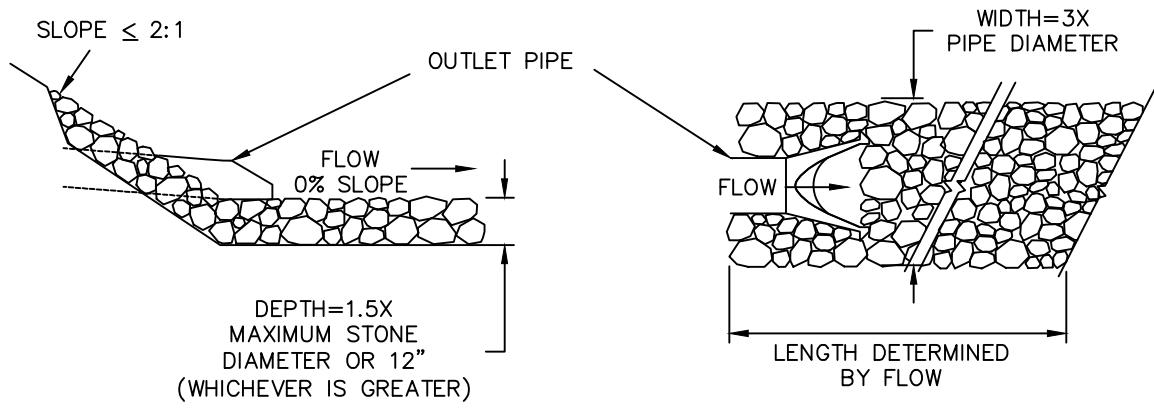

OUTLET POINT APPLICATION

SIZE OF TYPICAL RIPRAP STONES			
Weight (lbs.)	Average Spherical Diameter (in.) D <sub>50</sub>	Typical Rectangular Shape	
		Length (in.)	Width/Height (in.)
50	10	18	6
100	13	21	7
150	14	24	8
300	18	30	10
500	22	36	12
1000	27	45	15
1500	31	52	17
2000	34	57	19
4000	43	72	24
6000	49	83	28
8000	54	90	30

Source: Adapted from USDA NRCS

## APPLICATIONS

1. WHEN CONCENTRATED WATER FLOWS HAVE THE POTENTIAL TO CREATE SCOUR, DOWN-CUTTING, OR LATERAL CUTTING.
2. TO PREVENT LOSS OF LAND OR DAMAGE TO UTILITIES OR STRUCTURES. IN AQUATIC APPLICATIONS, RIPRAP IS USED TO CONTROL CHANNEL MEANDER AND MAINTAIN CAPACITY, PROTECT AGAINST WAVE ATTACK, AND REDUCE SEDIMENT LOAD.
3. ON SLOPES WITH PROFILES MEASURING 1:1.5 OR LESS.

## DESIGN

1. REVIEW SUBJECT SITE TO IDENTIFY AREAS SUBJECT TO CONCENTRATED FLOWS OR WAVE/CURRENT ATTACK.
2. THE AREA UNDER REVIEW FOR RIPRAP PLACEMENT MUST BE SHAPED AND CONTOURED APPROPRIATELY BY GRADING PRIOR TO MATERIAL PLACEMENT.
3. NON-WOVEN GEOTEXTILE FABRIC SHOULD BE INSTALLED PRIOR TO RIPRAP PLACEMENT, WITH UPPER END AND TOE END OF FABRIC BURIED OR ANCHORED TO PREVENT MOVEMENT.
4. RIPRAP PLACEMENT SHOULD BE STARTED AT A STABILIZED LOCATION AND ENDED AT A STABILIZED OR CONTOURED POINT.
5. MATERIAL SELECTED FOR RIPRAP SHOULD BE HARD, ANGULAR, AND RESISTANT TO WEATHERING. APPROPRIATE MATERIAL SIZE DEPENDS ON EXPECTED WATER ENERGY AND INTENDED FUNCTION OF THE MATERIAL.

## DESIGN (CONT.)

6. RIPRAP MIXTURE SHOULD BE AN EVEN MIXTURE OF STONE SIZES BASED ON THE AVERAGE, OR  $D_{50}$ . THIS MEANS 50% OF THE STONE, BY SIZE, WILL BE LARGER THAN THE DIAMETER SPECIFIED, AND 50% WILL BE SMALLER THAN THE SIZE SPECIFIED. THE DIAMETER OF THE LARGEST STONE SHOULD NOT BE MORE THAN 1.5 TIMES THE  $D_{50}$  STONE SIZE.
7. SEE TABLE ON THE PREVIOUS PAGE FOR TYPICAL RIPRAP STONE SIZES.
8. ROCK SHALL BE PLACED SO THAT LARGER ROCKS ARE UNIFORMLY DISTRIBUTED AND IN CONTACT WITH ONE ANOTHER. SMALLER ROCKS SHOULD FILL THE VOIDS.
9. WHEN IN CONTACT WITH MOVING WATER, RIPRAP WILL TIE INTO A STABLE BANK AT THE DOWNSTREAM END AND WILL BE KEYED INTO THE BANK AT THE UPSTREAM END. RIPRAP SHOULD EXTEND 3 FT. ABOVE THE ORDINARY HIGH WATER MARK OR TO THE TOP OF THE BANK ON SHORT SLOPES. EXTEND RIPRAP A MINIMUM 10 FT. BEYOND ACTIVE EROSION AREA.

THIS PAGE INTENTIONALLY LEFT BLANK

THIS PAGE INTENTIONALLY LEFT BLANK

THIS PAGE INTENTIONALLY LEFT BLANK



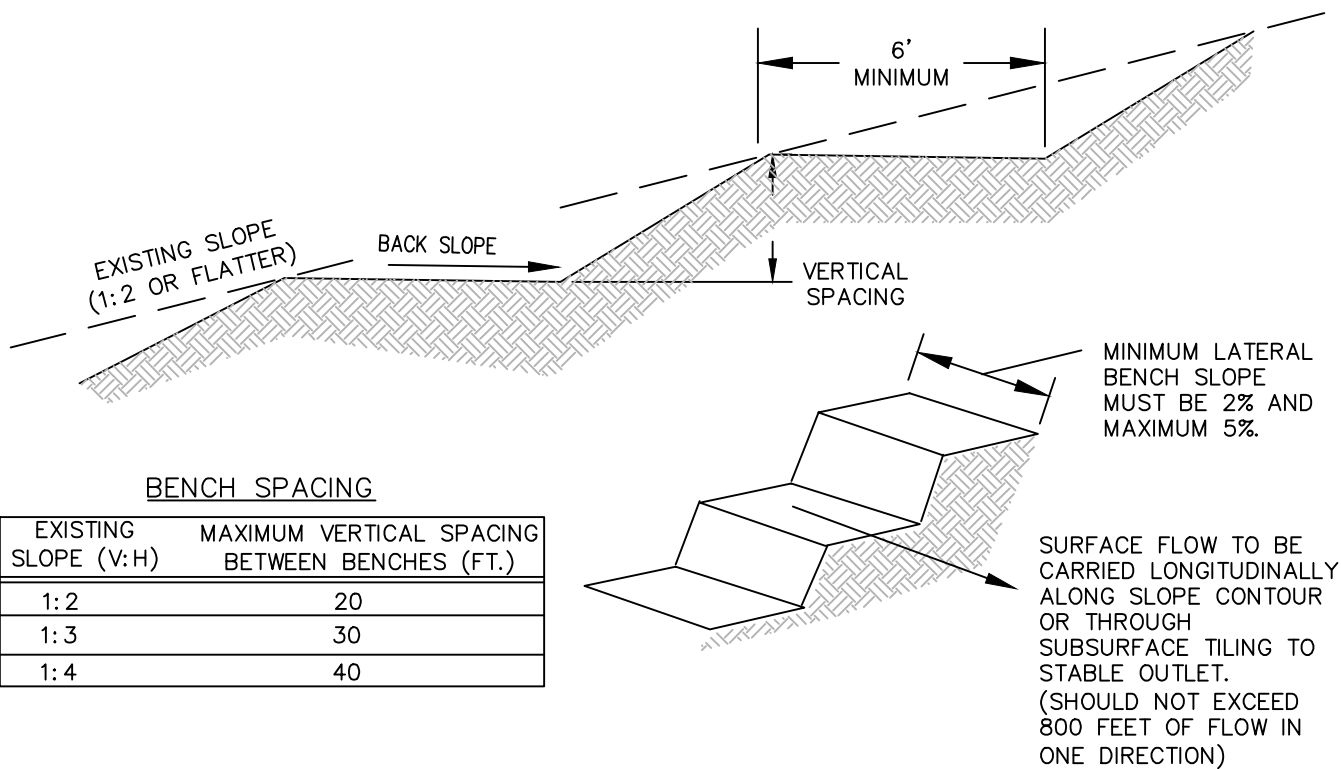

BENCH SPACING

EXISTING SLOPE (V:H)	MAXIMUM VERTICAL SPACING BETWEEN BENCHES (FT.)
1:2	20
1:3	30
1:4	40

TYPICAL BENCH DETAIL

APPLICATIONS

1. WHEN SURFACE WATER RUNOFF ONTO STEEP SLOPES HAS THE POTENTIAL TO CAUSE SEDIMENTATION.
2. TO REDUCE RUNOFF VELOCITIES, MINIMIZE SEDIMENTATION, INCREASE INFILTRATION, TO PROVIDE ACCESS TO STEEPER SLOPES FOR CONSTRUCTION OR MAINTENANCE PURPOSES, AND TO ALLOW FOR VEGETATION ESTABLISHMENT.
3. ON RELATIVELY LONG SLOPES WITH FAIRLY STABLE SOILS.

DESIGN

1. FACTORS TO BE CONSIDERED INCLUDE SLOPE STEEPNESS, EXPECTED RUNOFF VELOCITIES, EXISTING SOIL TYPE, SLOPE FORMATION (CUT VS. FILL), SLOPE LENGTH, AND MOWING OR EQUIPMENT ACCESS REQUIREMENTS.
2. REVIEW SITE AND SITE PLAN TO IDENTIFY LONG SLOPES STEEPER THAN 1:3.
3. LOCATE BENCHES ALONG CONTOURS PERPENDICULAR TO SLOPE DIRECTION.
4. BENCHES CAN BE CONSTRUCTED WITH A SLIGHT CROSS-SLOPE GRADE TO DIVERT SURFACE RUNOFF TO STABILIZED OUTLET LOCATIONS. UNDERGROUND TILING ON BENCHES CAN FACILITATE CONTROL OF RUNOFF.
5. SLIGHT BACK SLOPING OF BENCH INTO EXISTING SLOPE WILL PROMOTE INFILTRATION/REDUCE SURFACE WATER RUNOFF.
6. BENCHES CAN BE ESTABLISHED BY CUTTING FURROWS OR CARVING SHELVES ALONG PARALLEL SLOPE CONTOURS.

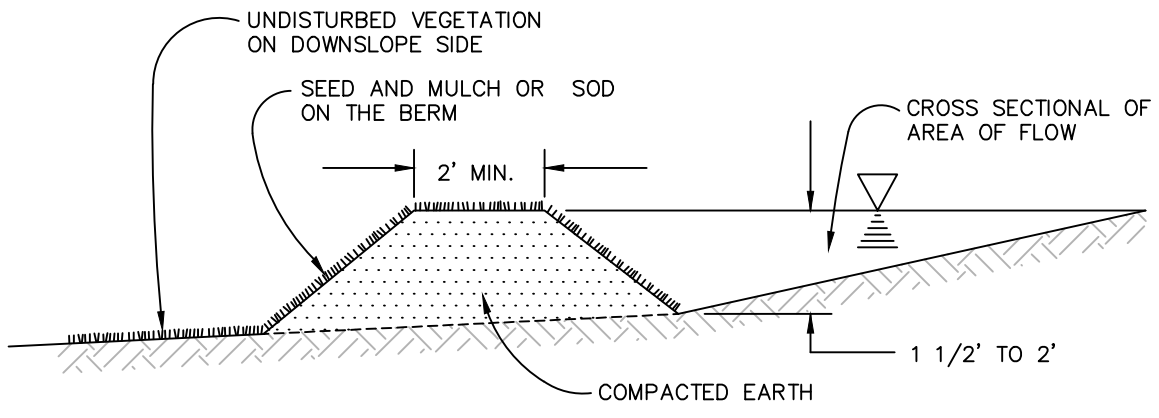

CROSS SECTION

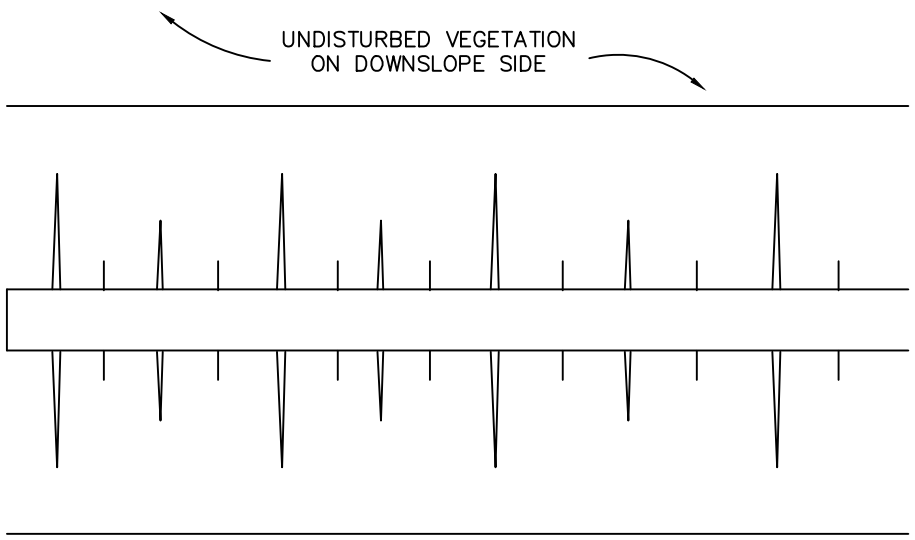

PLAN VIEW

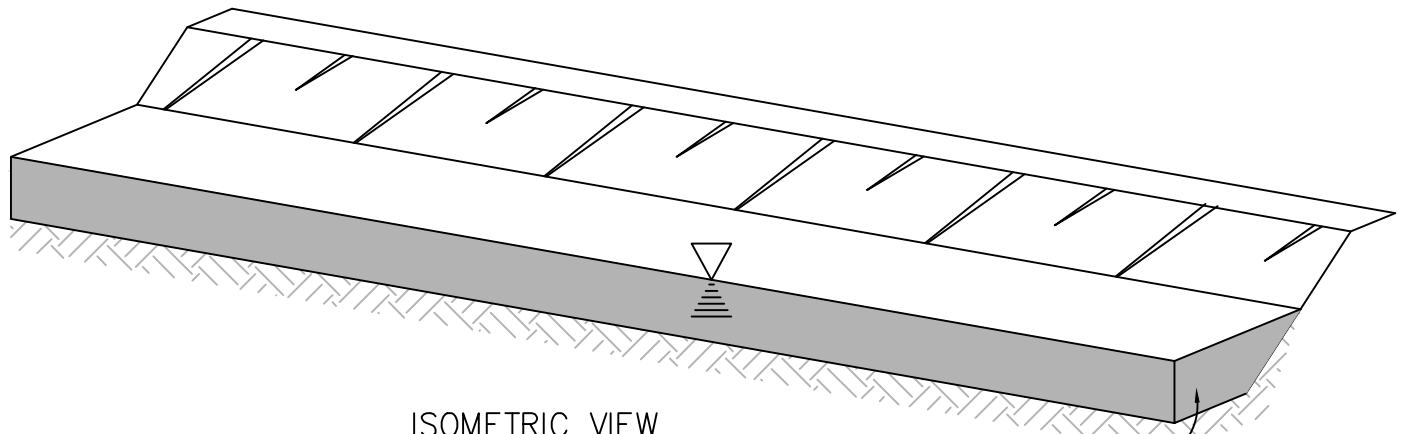

ISOMETRIC VIEW

WATER BEING DIVERTED

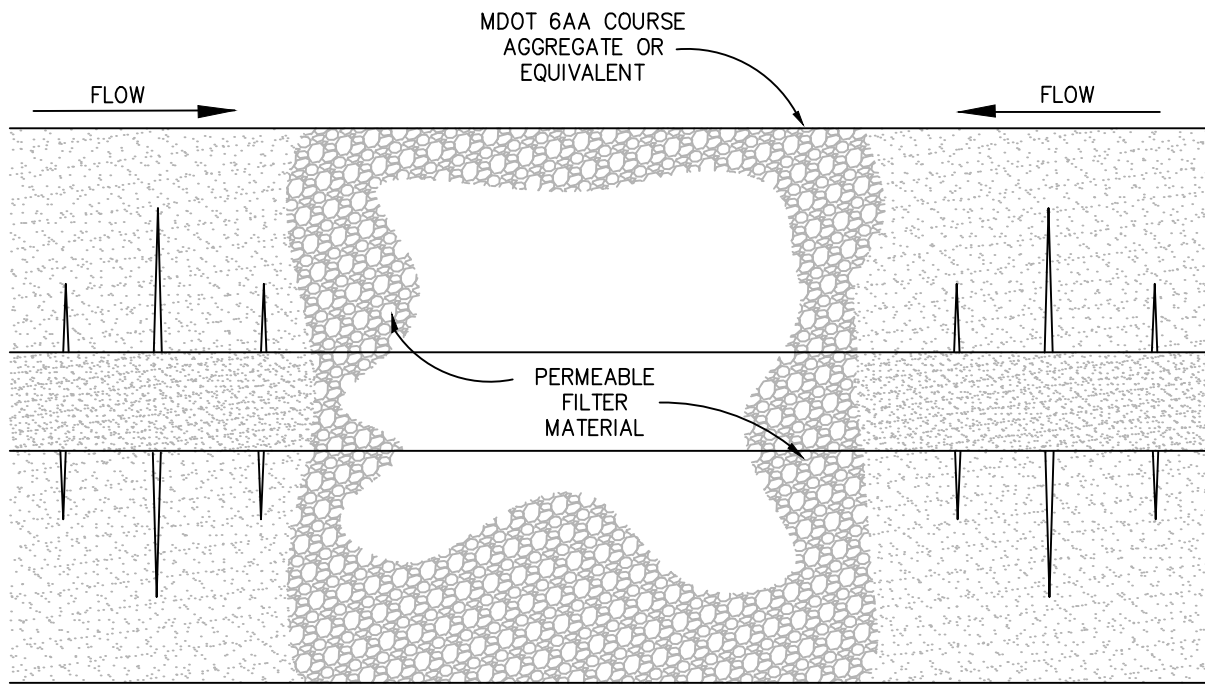

PLAN VIEW

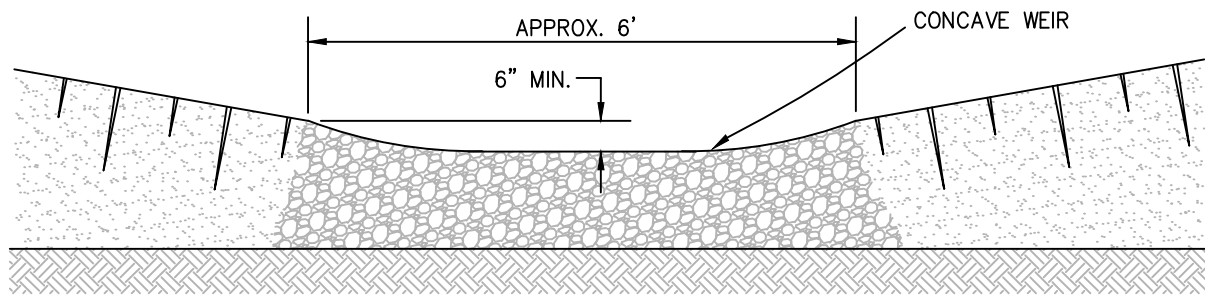

FRONT VIEW

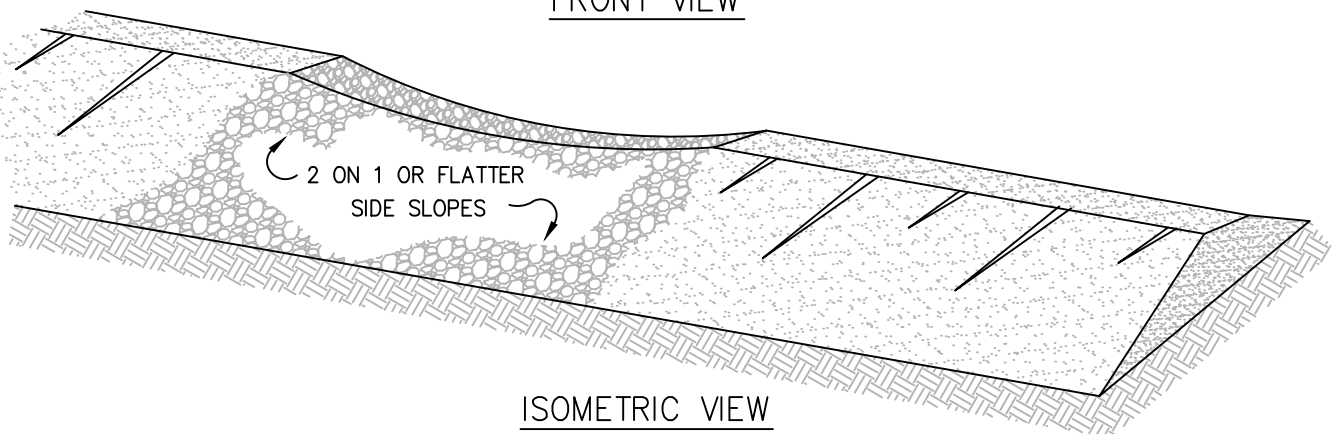

ISOMETRIC VIEW

EARTH DIVERSION BERM  
WITH STONE OUTLET FILTER

18A

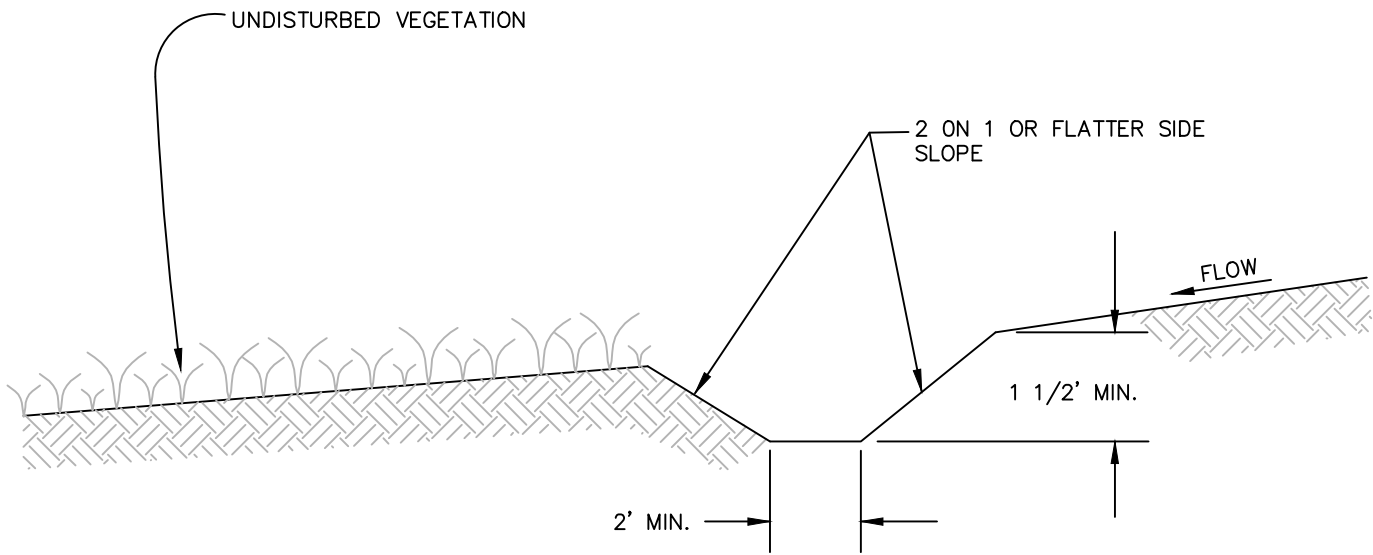

CROSS SECTION

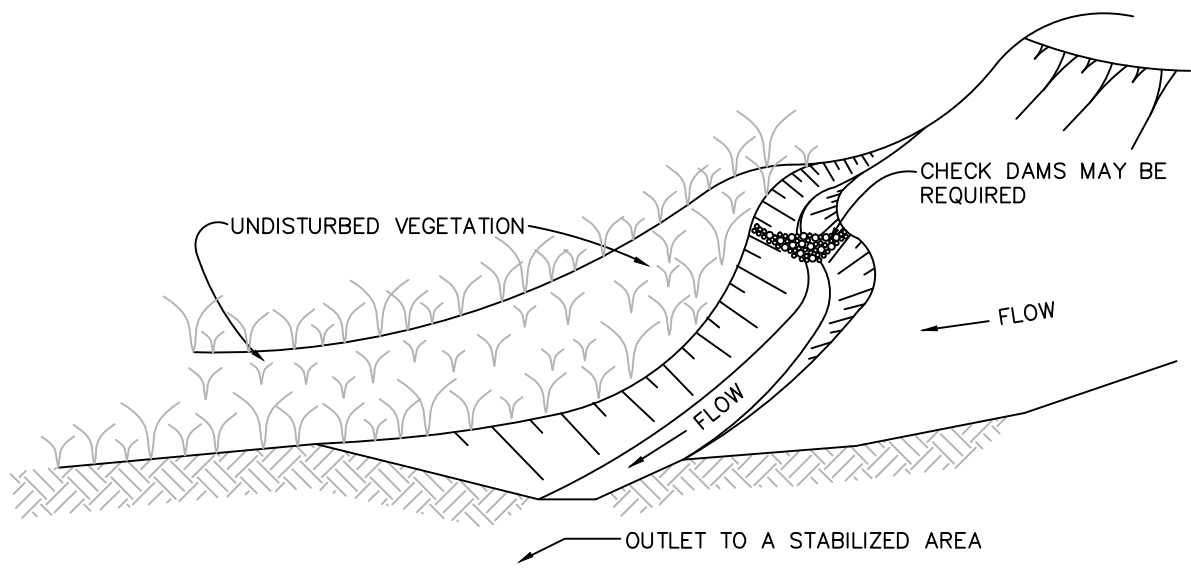

ISOMETRIC VIEW

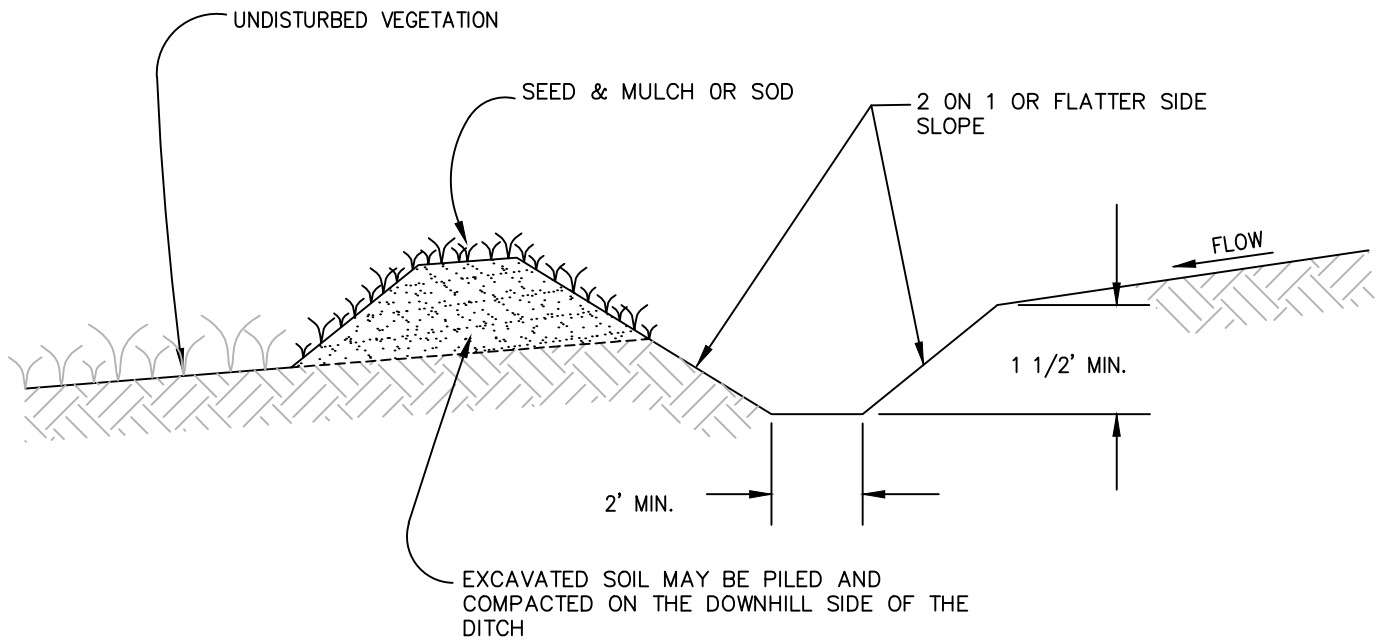

CROSS SECTION

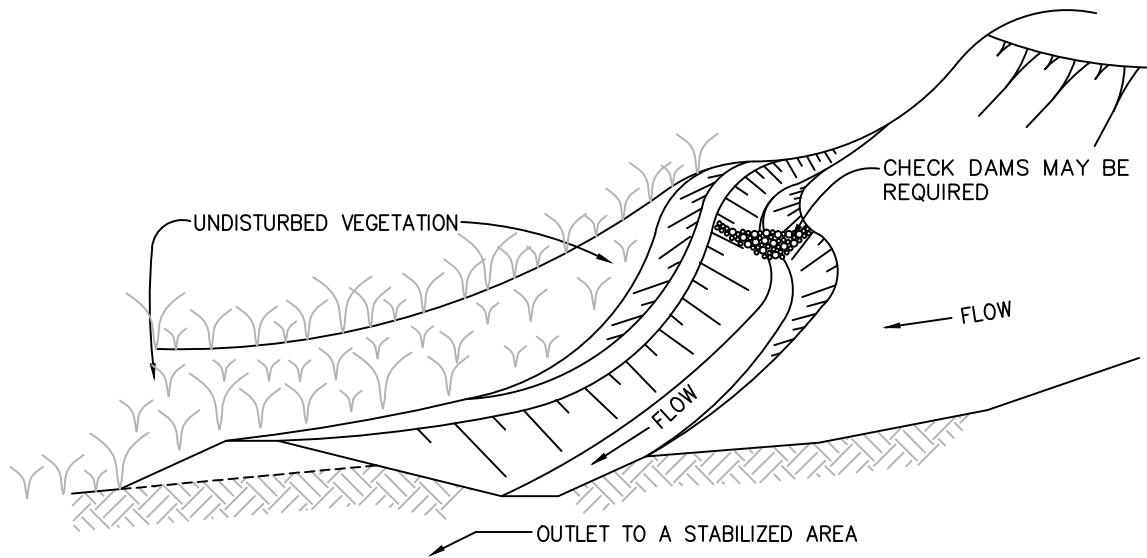

ISOMETRIC VIEW

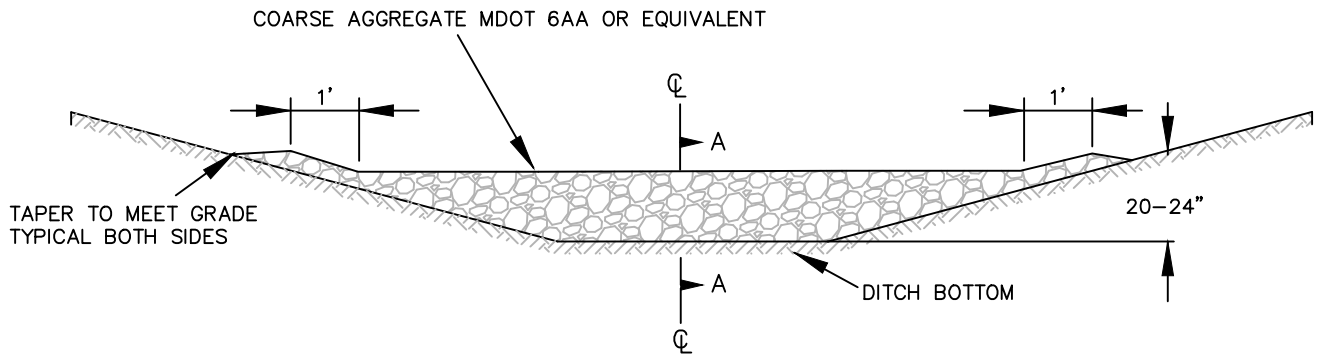

DITCH CROSS SECTION

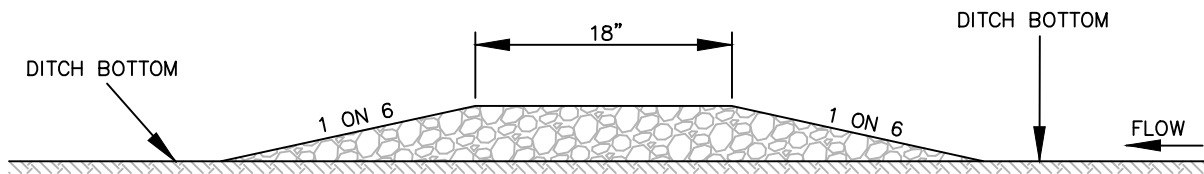

SECTION A - A

APPLICATION

1. FILTER WATER BEFORE LEAVES SITE TO REDUCE SEDIMENT.
2. DO NOT USE AS A CHECK DAM.

WARNINGS

1. WARNING! THIS DEVICE MAY CAUSE FLOODING OF ADJACENT PROPERTY.

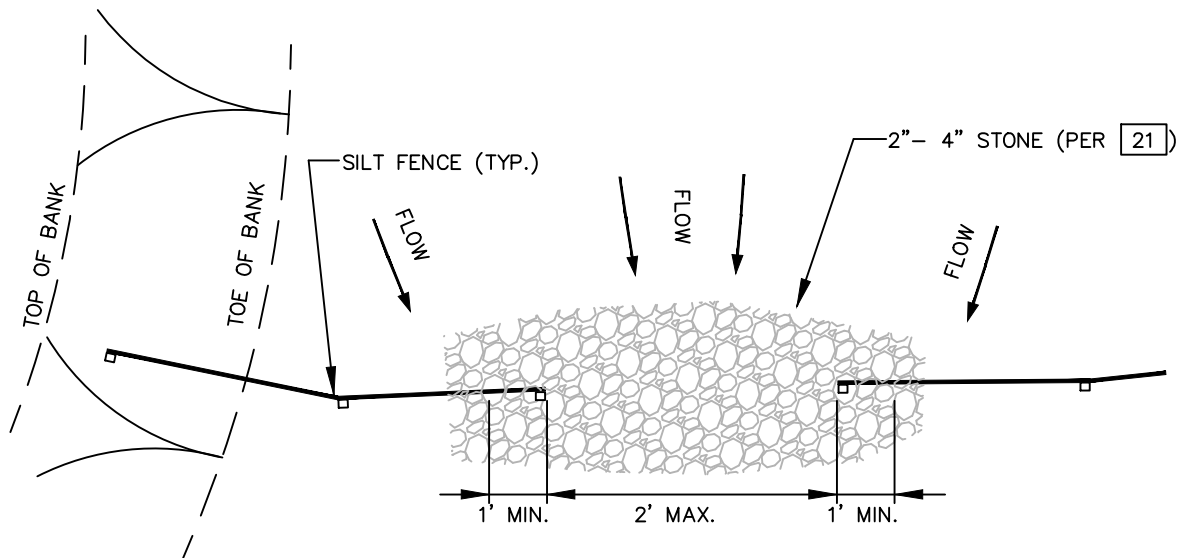

PLAN

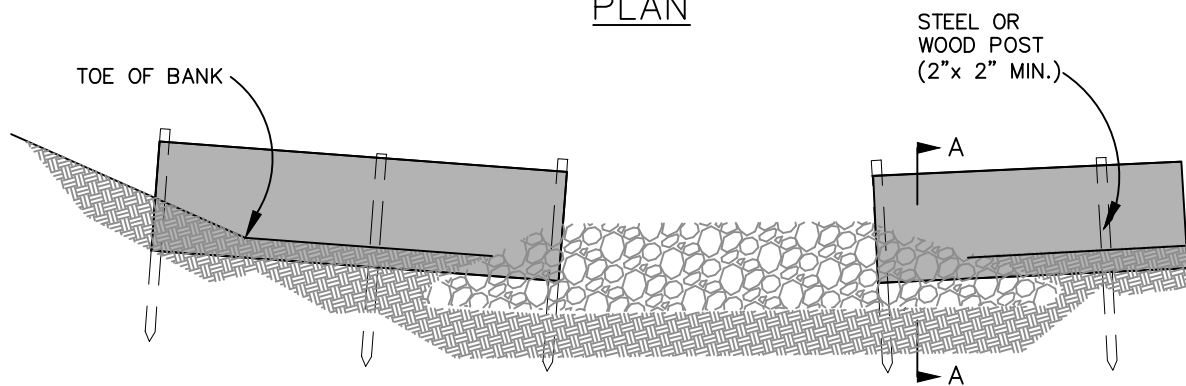

VIEW LOOKING UPSTREAM

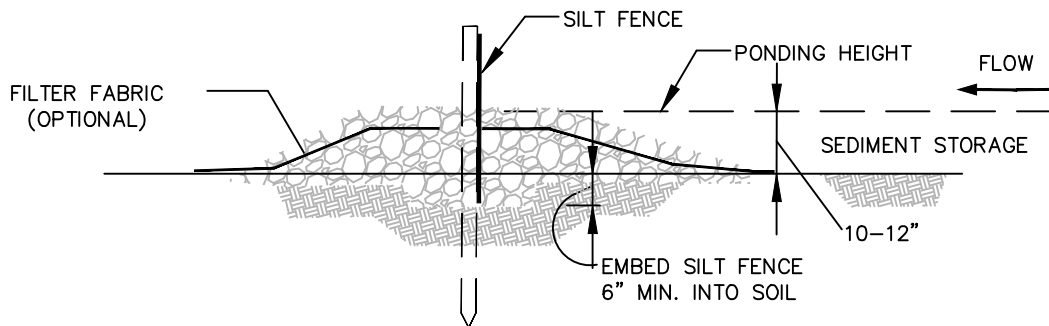

SECTION A-A

APPLICATIONS

1. SHALLOW SWALES AND ROADSIDE DITCHES.
2. LONG SECTIONS OF SILT FENCE WHERE "BLOW OUT" CAN BE EXPECTED.

DESIGN

1. PLACE SILT FENCE PERPENDICULAR TO FLOW.

DESIGN (CONT)

2. INSTALL THE SILT FENCE PER [ 54 ].
3. FILTER FABRIC MUST KEY INTO STONE SPILLWAY TO PREVENT EROSION OR FLOW AROUND THE SPILLWAY.
4. SILT FENCE SHALL BE HIGHER THAN ROCK DAM.

STONE FILTER BERM WITH SILT FENCE [ 21A ]

THIS PAGE INTENTIONALLY LEFT BLANK



THIS PAGE INTENTIONALLY LEFT BLANK

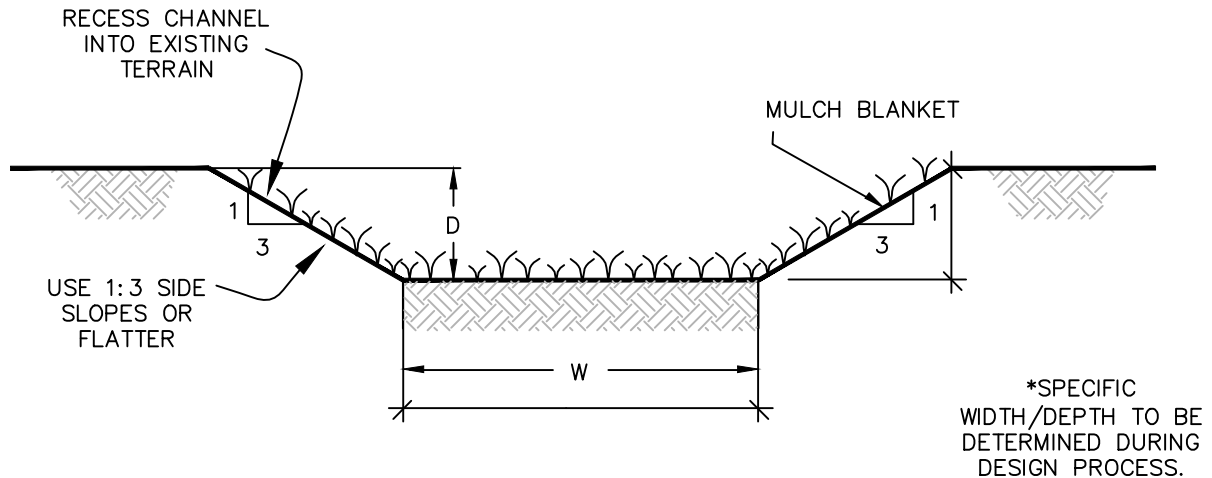



CHANNEL CROSS-SECTION

APPLICATIONS

1. WHEN SURFACE FLOW VELOCITIES WITHIN A CREATED STORMWATER CHANNEL HAVE THE POTENTIAL TO CAUSE EROSION.
2. TO SLOW WATER VELOCITY AND REDUCE EROSION AND SEDIMENT LOADING IN THE STORMWATER CHANNEL.
3. FOR USE IN CONSTRUCTED DRAINAGEWAYS WHERE RUN-OFF MAY CAUSE EROSION.

DESIGN

1. REVIEW SUBJECT SITE TO IDENTIFY CHANNEL AREAS POTENTIALLY SUSCEPTIBLE TO HIGH FLOWS, EROSION VELOCITIES OR FLOODING.
2. CONSULT A PROFESSIONAL LANDSCAPE ARCHITECT, PROFESSIONAL ENGINEER OR CPESC REGARDING CONSIDERATIONS OF CHANNEL DESIGN BASED ON WATER VELOCITY, CHANNEL SLOPE, DISCHARGE VOLUME AND SOIL TYPE.
3. GENERAL CAPACITY REQUIREMENTS SHOULD ALLOW FOR CONVEYANCE OF A 10-YEAR, 24-HOUR RAIN EVENT AT A MINIMUM.
4. CHANNEL SHAPE SHOULD EITHER BE PARABOLIC  OR  TRAPEZOIDAL. V-SHAPED CHANNELS ARE NOT RECOMMENDED AS THEY FORM GULLIES AND INCREASE THE EROSION POTENTIAL.
5. ALL VEGETATED CHANNELS SHOULD HAVE A DEPTH OF ONE FOOT OR MORE.

DESIGN (CONT)

6. EXCAVATE OR GRADE CHANNEL SURFACE ACCORDING TO DESIGN. LOCATE CHANNELS IN NATURAL TOPOGRAPHIC DEPRESSIONS WHERE POSSIBLE. RECESS CHANNEL INTO EXISTING GRADE SO THAT CHANNEL TOP IS FLUSH WITH ADJACENT GRADE.
7. DETERMINE VEGETATIVE SPECIES BASED ON THE DEPTH TO WATER TABLE, CLIMATE, ANTICIPATED FLOW VELOCITIES, AND FINAL MANAGED LENGTH OF VEGETATION. UTILIZE NATIVE SPECIES FOR VEGETATION PURPOSES.
8. IN CHANNELS TO BE SEED, PREPARE SEEDBED, APPLY SEED, AND INSTALL MULCH BLANKET/TRM.
9. IN CHANNELS PLANTED WITH VEGETATIVE PLUGS OR SEEDLINGS, PREPARE CHANNEL, AND INSTALL MULCH BLANKET/TRM.
10. NOT RECOMMENDED TO USE DORMANT SEEDINGS DUE TO HIGH FAILURE RATE.
11. ESTABLISH VEGETATED CHANNEL PRIOR TO PERIODS OF HIGH RUN-OFF.
12. PRIOR TO CONSTRUCTION WORK IN AREA SURROUNDING CHANNEL, ALLOW VEGETATION IN CHANNEL TO ESTABLISH.
13. CHECK DAMS OR VELOCITY DISSIPATORS MAY BE NEEDED UNTIL VEGETATION IS ESTABLISHED.

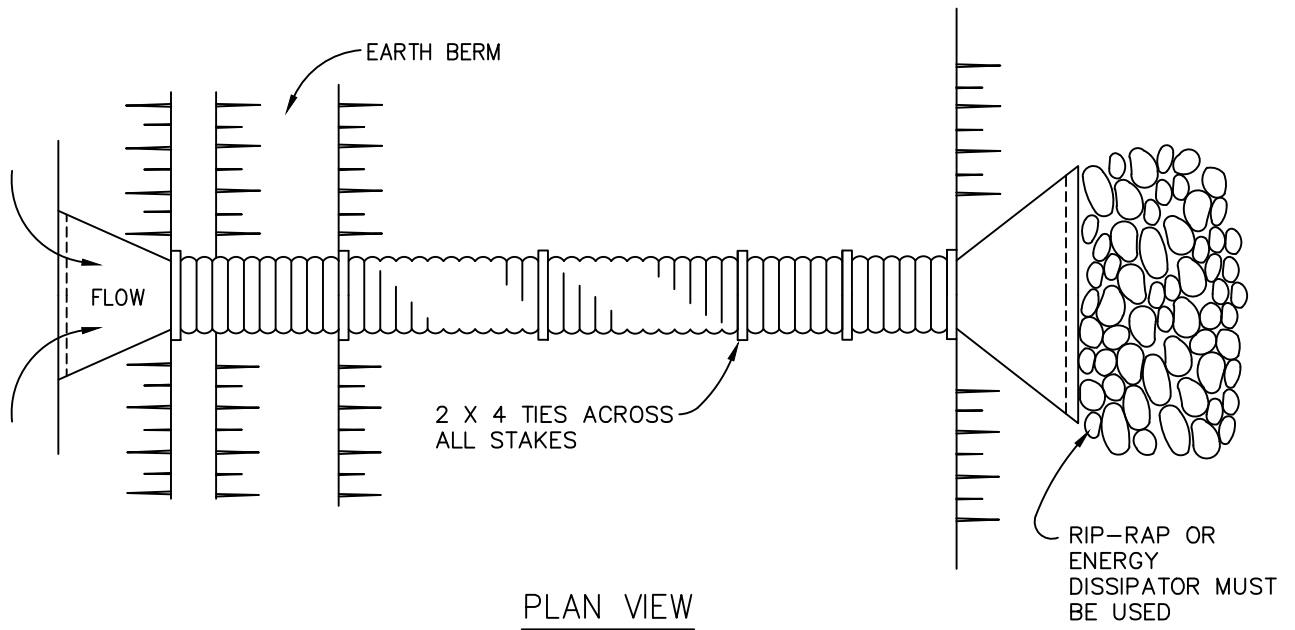

PLAN VIEW

SEE 13 FOR RIP-RAP

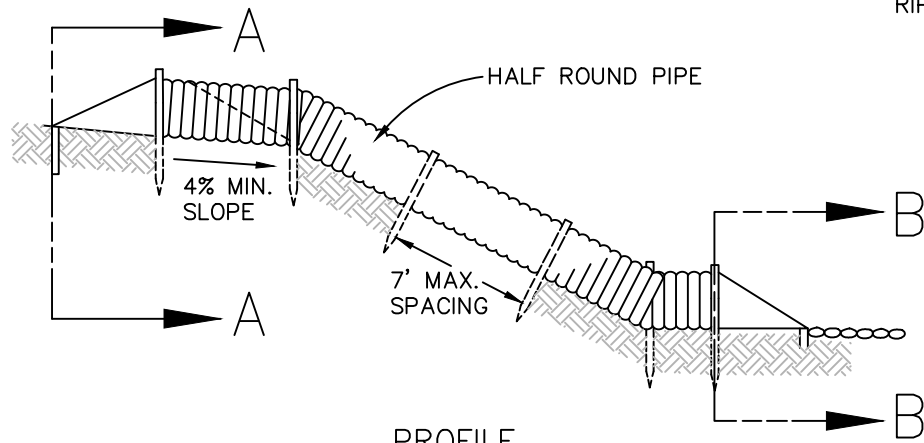

PROFILE

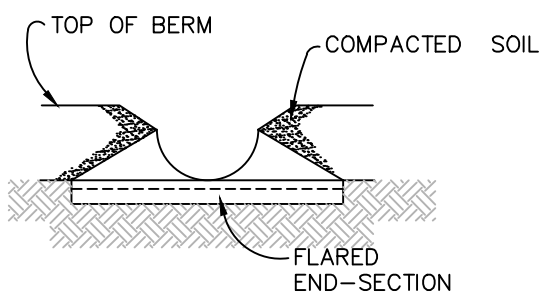

SECTION A-A

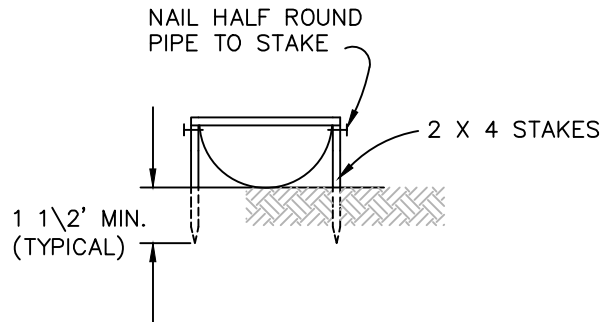

SECTION B-B

SLOPE DRAIN - SURFACE PIPE 25

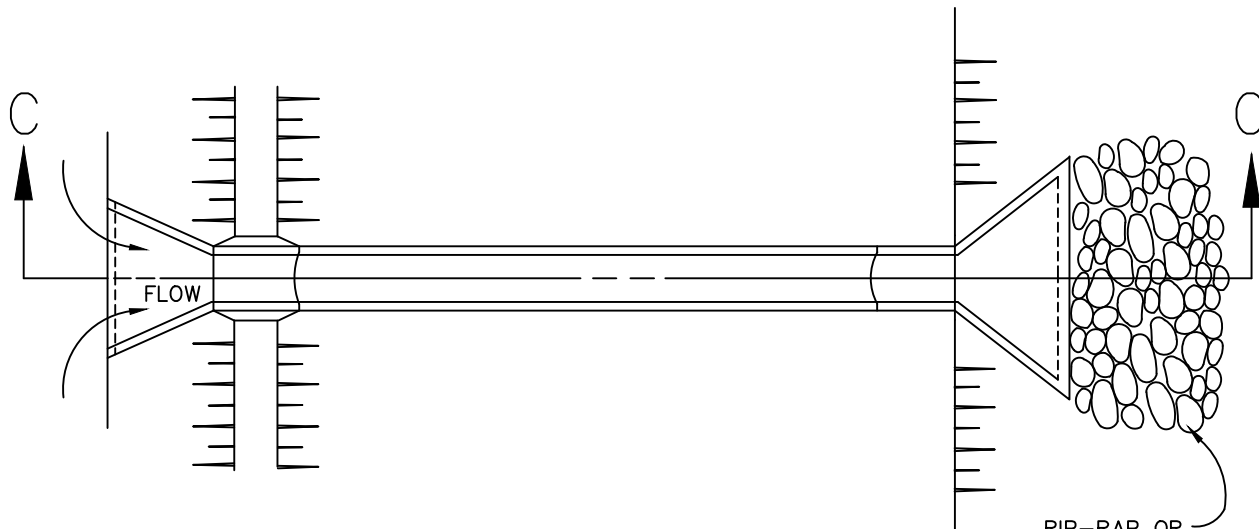

PLAN VIEW

RIP-RAP OR ENERGY DISSIPATOR MUST BE USED

SEE 13 FOR RIP-RAP

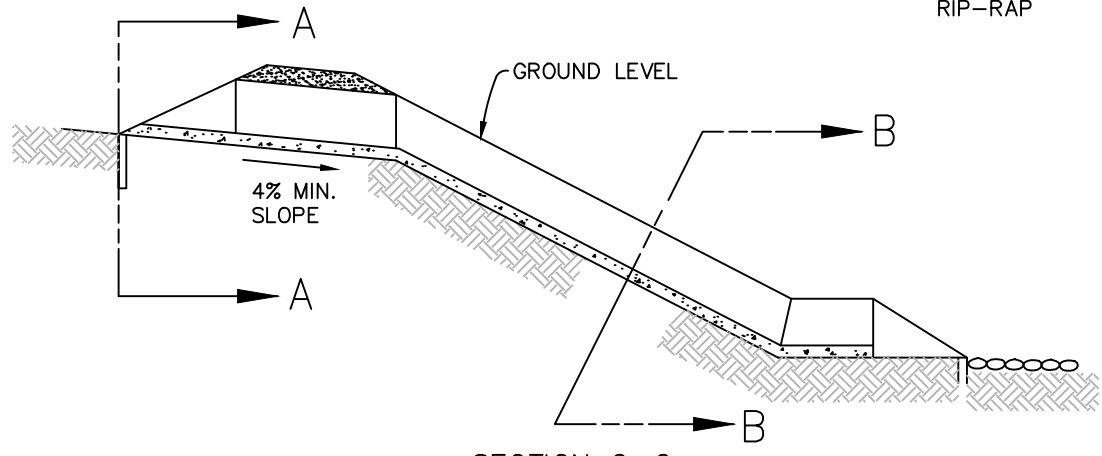

SECTION C-C

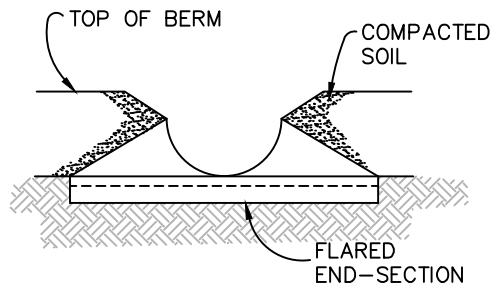

SECTION A-A

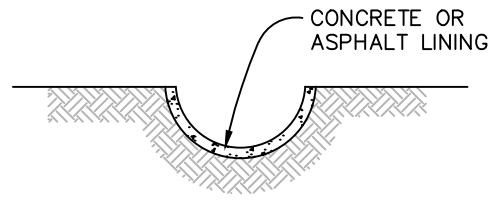

SECTION B-B

DESIGN CRITERIA FOR  
PIPE SLOPE DRAIN

PIPE DIAMETER (IN.)	MAXIMUM DRAINAGE AREA (ACRES)
12	0.5
18	1.5
21	2.5
24	3.5
(2) 24	5.0

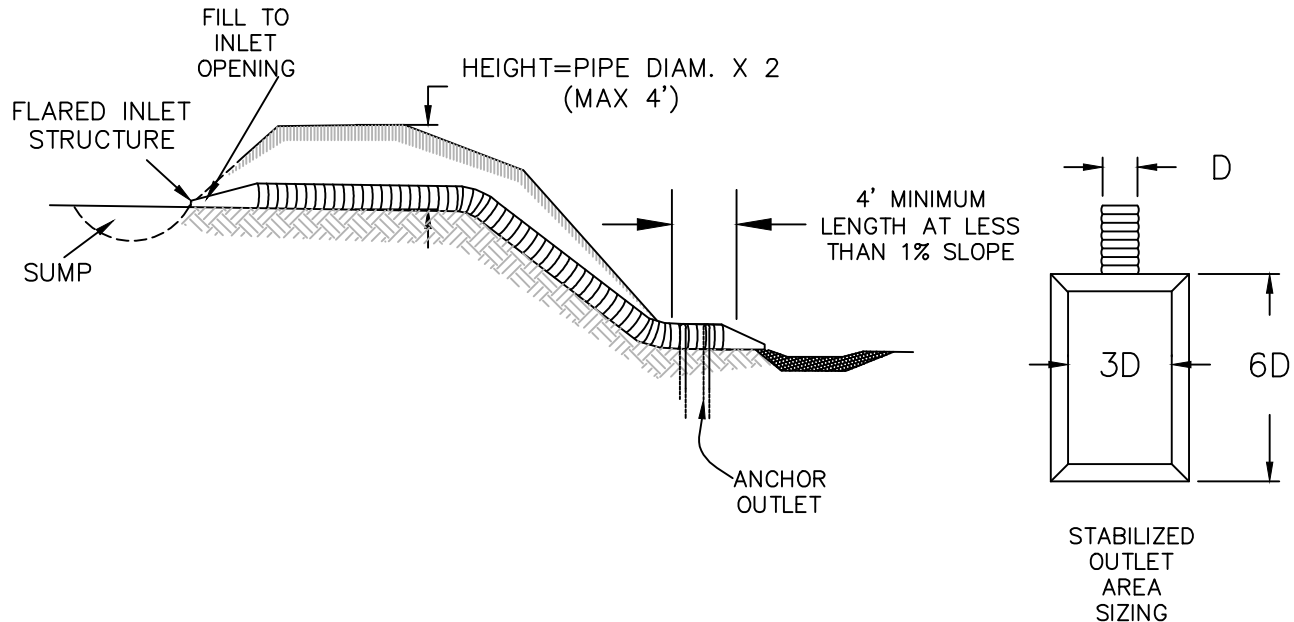
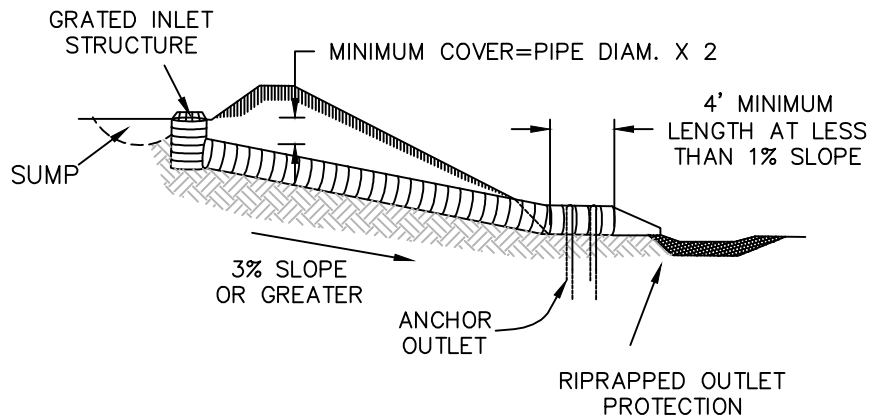

APPLICATIONS

1. WHEN SURFACE RUNOFF ACCUMULATES AT THE TOP OF A SLOPE AND REQUIRES PERMANENT CONVEYANCE TO SLOPE BOTTOM TO MINIMIZE EROSION.
2. TO ELIMINATE SLOPE EROSION, GULLY FORMATION, AND SLOPE FAILURE.
3. WHERE CONCENTRATED FLOW OF SURFACE RUNOFF MUST BE PERMANENTLY CONVEYED DOWN A SLOPE IN ORDER TO PREVENT EROSION.
4. TO PROVIDE PERMANENT DRAINAGE FOR TOP OF SLOPE DIVERSION DIKES OR SWALES.

DESIGN

1. UTILIZE GRADING PLAN TO IDENTIFY PERMANENT SLOPE TOP RUNOFF/STORMWATER CONCENTRATION POINTS.

DESIGN (CONT)

2. SELECT APPROPRIATE PIPE SIZE. SIZE SHOULD NOT BE LESS THAN SPECIFIED IN DESIGN CRITERIA TABLE. UNLESS OTHERWISE SPECIFIED, TEMPORARY DRAINS SHOULD BE SUFFICIENT TO HANDLE PEAK RUNOFF FROM A 10-YEAR, 24-HOUR RAINFALL EVENT.
3. CONSTRUCT THE PIPE SLOPE DRAIN ENTRANCE USING A DROP PIPE WITH A SCREENED INLET (ALTERNATIVE: A STANDARD FLARED INLET). THE SLOPE OF THE ENTRANCE IS USUALLY AT LEAST 3 PERCENT.
4. UTILIZE ANTI-SEEP WATERTIGHT COLLARS TO JOIN PIPE SECTIONS.
5. THOROUGHLY COMPACT THE SOIL AROUND AND UNDER THE PIPE AND ENTRANCE SECTION IN MULTIPLE LIFTS.
6. STABILIZE OUTLET WITH RIPRAP. RIPRAP SHOULD CONSIST OF 6" DIAMETER STONE PLACED ACCORDING TO VOLUME OF DISCHARGE EXPECTED.

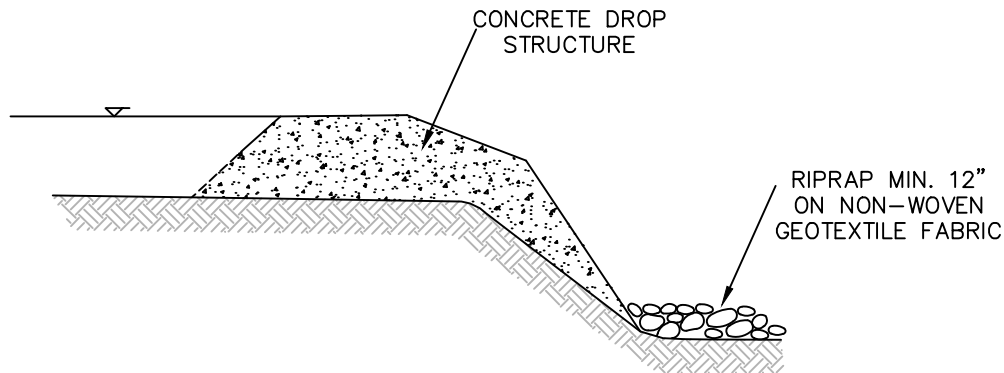

#### APPLICATIONS

1. WHEN SURFACE RUNOFF ACCUMULATES AT THE TOP OF A SLOPE AND REQUIRES PERMANENT CONVEYANCE TO SLOPE BOTTOM TO MINIMIZE EROSION.
2. TO ELIMINATE SLOPE EROSION, GULLY FORMATION, AND SLOPE FAILURE.
3. WHERE CONCENTRATED FLOW OF SURFACE RUNOFF MUST BE PERMANENTLY CONVEYED DOWN A SLOPE IN ORDER TO PREVENT EROSION.
4. TO PROVIDE PERMANENT DRAINAGE FOR TOP OF SLOPE DIVERSION DIKES OR SWALES.

#### DESIGN

1. UTILIZE GRADING PLAN TO IDENTIFY PERMANENT SLOPE TOP RUNOFF/STORMWATER CONCENTRATION POINTS.

#### DESIGN (CONT)

2. SELECT APPROPRIATE PIPE SIZE. SIZE SHOULD NOT BE LESS THAN SPECIFIED IN DESIGN CRITERIA TABLE. UNLESS OTHERWISE SPECIFIED, TEMPORARY DRAINS SHOULD BE SUFFICIENT TO HANDLE PEAK RUNOFF FROM A 10-YEAR, 24-HOUR RAINFALL EVENT.
3. CONSTRUCT THE PIPE SLOPE DRAIN ENTRANCE USING A DROP PIPE WITH A SCREENED INLET (ALTERNATIVE: A STANDARD FLARED INLET). THE SLOPE OF THE ENTRANCE IS USUALLY AT LEAST 3 PERCENT.
4. UTILIZE ANTI-SEEP WATERTIGHT COLLARS TO JOIN PIPE SECTIONS.
5. THOROUGHLY COMPACT THE SOIL AROUND AND UNDER THE PIPE AND ENTRANCE SECTION IN MULTIPLE LIFTS.
6. STABILIZE OUTLET WITH RIPRAP. RIPRAP SHOULD CONSIST OF 6" DIAMETER STONE PLACED ACCORDING TO VOLUME OF DISCHARGE EXPECTED.

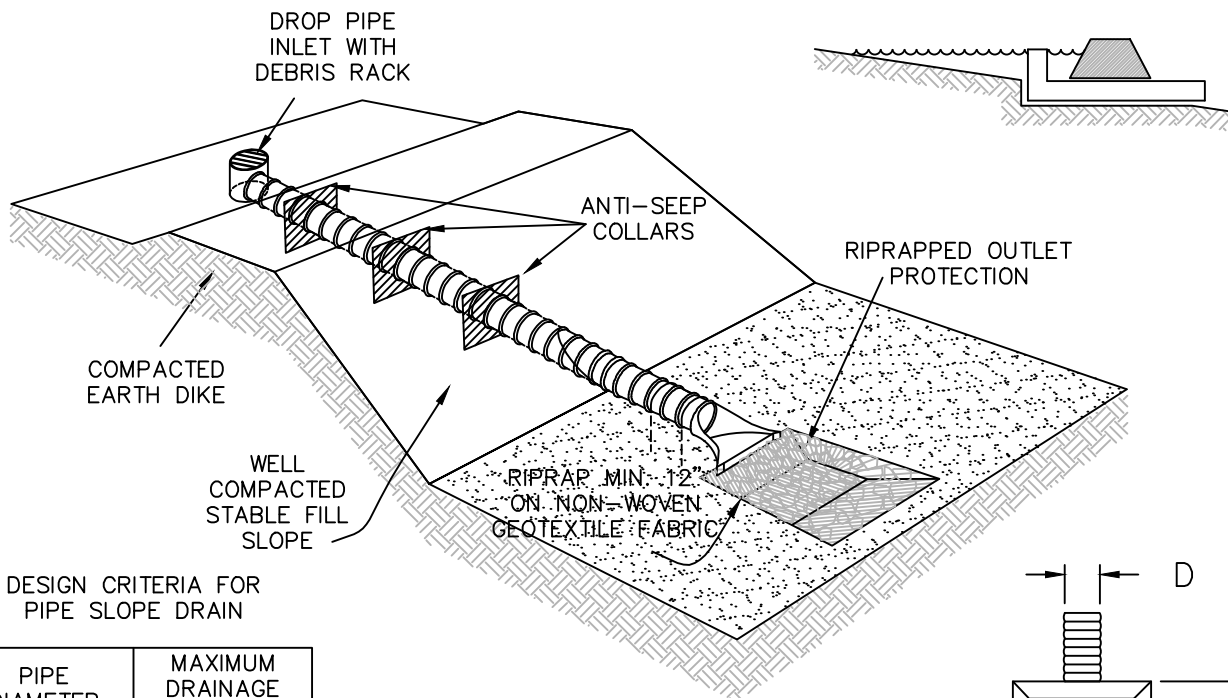

DESIGN CRITERIA FOR PIPE SLOPE DRAIN

PIPE DIAMETER (IN.)	MAXIMUM DRAINAGE AREA (ACRES)
12	0.5
18	1.5
21	2.5
24	3.5
(2) 24	5.0

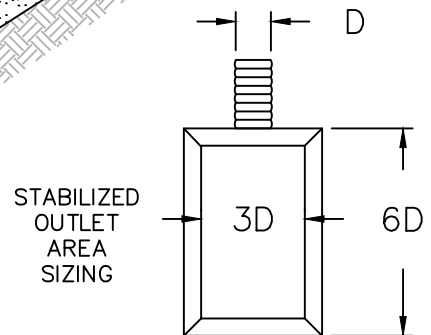

### APPLICATIONS

1. WHEN SURFACE RUNOFF ACCUMULATES AT THE TOP OF A SLOPE AND REQUIRES PERMANENT CONVEYANCE TO SLOPE BOTTOM TO MINIMIZE EROSION.
2. TO ELIMINATE SLOPE EROSION, GULLY FORMATION, AND SLOPE FAILURE.
3. WHERE CONCENTRATED FLOW OF SURFACE RUNOFF MUST BE PERMANENTLY CONVEYED DOWN A SLOPE IN ORDER TO PREVENT EROSION.
4. TO PROVIDE PERMANENT DRAINAGE FOR TOP OF SLOPE DIVERSION DIKES OR SWALES.

### DESIGN

1. UTILIZE GRADING PLAN TO IDENTIFY PERMANENT SLOPE TOP RUNOFF/STORMWATER CONCENTRATION POINTS.

### DESIGN (CONT)

2. SELECT APPROPRIATE PIPE SIZE. SIZE SHOULD NOT BE LESS THAN SPECIFIED IN DESIGN CRITERIA TABLE. UNLESS OTHERWISE SPECIFIED, TEMPORARY DRAINS SHOULD BE SUFFICIENT TO HANDLE PEAK RUNOFF FROM A 10-YEAR, 24-HOUR RAINFALL EVENT.
3. CONSTRUCT THE PIPE SLOPE DRAIN ENTRANCE USING A DROP PIPE WITH A SCREENED INLET (ALTERNATIVE: A STANDARD FLARED INLET). THE SLOPE OF THE ENTRANCE IS USUALLY AT LEAST 3 PERCENT.
4. UTILIZE ANTI-SEEP WATERTIGHT COLLARS TO JOIN PIPE SECTIONS.
5. THOROUGHLY COMPACT THE SOIL AROUND AND UNDER THE PIPE AND ENTRANCE SECTION IN MULTIPLE LIFTS.
6. STABILIZE OUTLET WITH RIPRAP. RIPRAP SHOULD CONSIST OF 6" DIAMETER STONE PLACED ACCORDING TO VOLUME OF DISCHARGE EXPECTED.

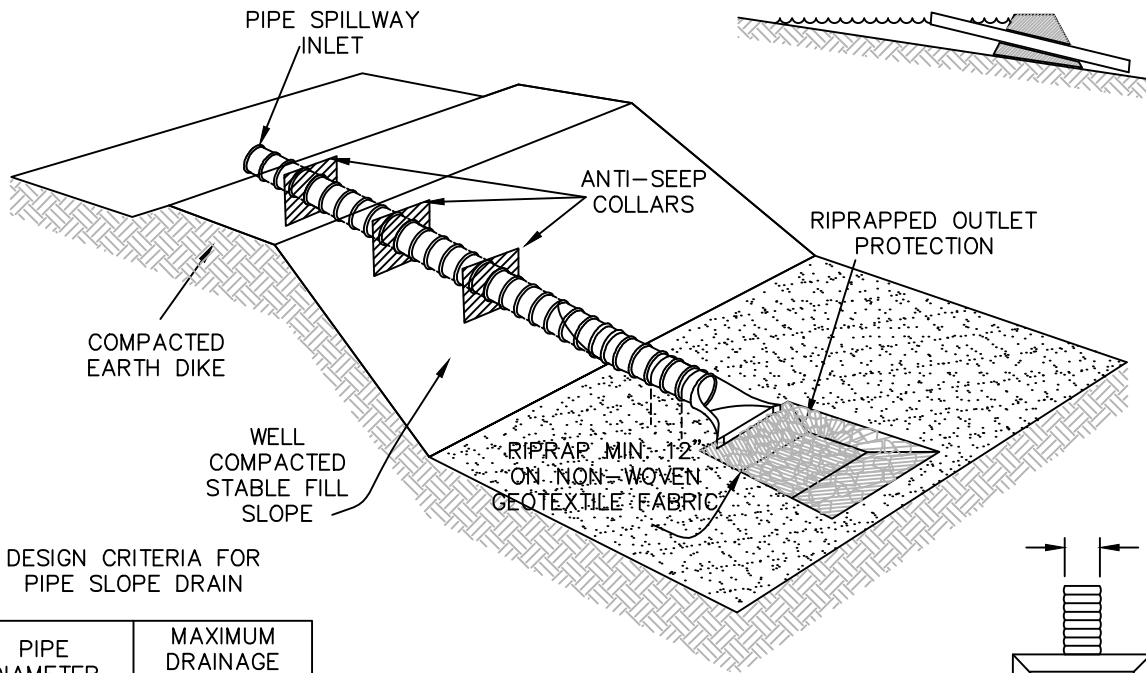

DESIGN CRITERIA FOR  
PIPE SLOPE DRAIN

PIPE DIAMETER (IN.)	MAXIMUM DRAINAGE AREA (ACRES)
12	0.5
18	1.5
21	2.5
24	3.5
(2) 24	5.0

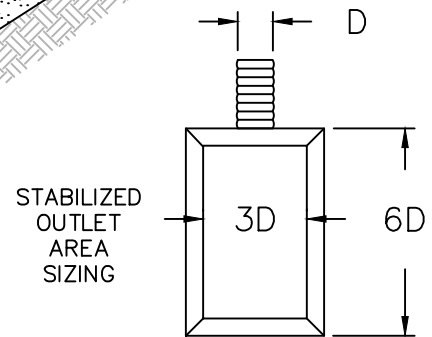

### APPLICATIONS

1. WHEN SURFACE RUNOFF ACCUMULATES AT THE TOP OF A SLOPE AND REQUIRES PERMANENT CONVEYANCE TO SLOPE BOTTOM TO MINIMIZE EROSION.
2. TO ELIMINATE SLOPE EROSION, GULLY FORMATION, AND SLOPE FAILURE.
3. WHERE CONCENTRATED FLOW OF SURFACE RUNOFF MUST BE PERMANENTLY CONVEYED DOWN A SLOPE IN ORDER TO PREVENT EROSION.
4. TO PROVIDE PERMANENT DRAINAGE FOR TOP OF SLOPE DIVERSION DIKES OR SWALES.

### DESIGN

1. UTILIZE GRADING PLAN TO IDENTIFY PERMANENT SLOPE TOP RUNOFF/STORMWATER CONCENTRATION POINTS.

### DESIGN (CONT)

2. SELECT APPROPRIATE PIPE SIZE. SIZE SHOULD NOT BE LESS THAN SPECIFIED IN DESIGN CRITERIA TABLE. UNLESS OTHERWISE SPECIFIED, TEMPORARY DRAINS SHOULD BE SUFFICIENT TO HANDLE PEAK RUNOFF FROM A 10-YEAR, 24-HOUR RAINFALL EVENT.
3. CONSTRUCT THE PIPE SLOPE DRAIN ENTRANCE USING A DROP PIPE WITH A SCREENED INLET (ALTERNATIVE: A STANDARD FLARED INLET). THE SLOPE OF THE ENTRANCE IS USUALLY AT LEAST 3 PERCENT.
4. UTILIZE ANTI-SEEP WATERTIGHT COLLARS TO JOIN PIPE SECTIONS.
5. THOROUGHLY COMPACT THE SOIL AROUND AND UNDER THE PIPE AND ENTRANCE SECTION IN MULTIPLE LIFTS.
6. STABILIZE OUTLET WITH RIPRAP. RIPRAP SHOULD CONSIST OF 6" DIAMETER STONE PLACED ACCORDING TO VOLUME OF DISCHARGE EXPECTED.



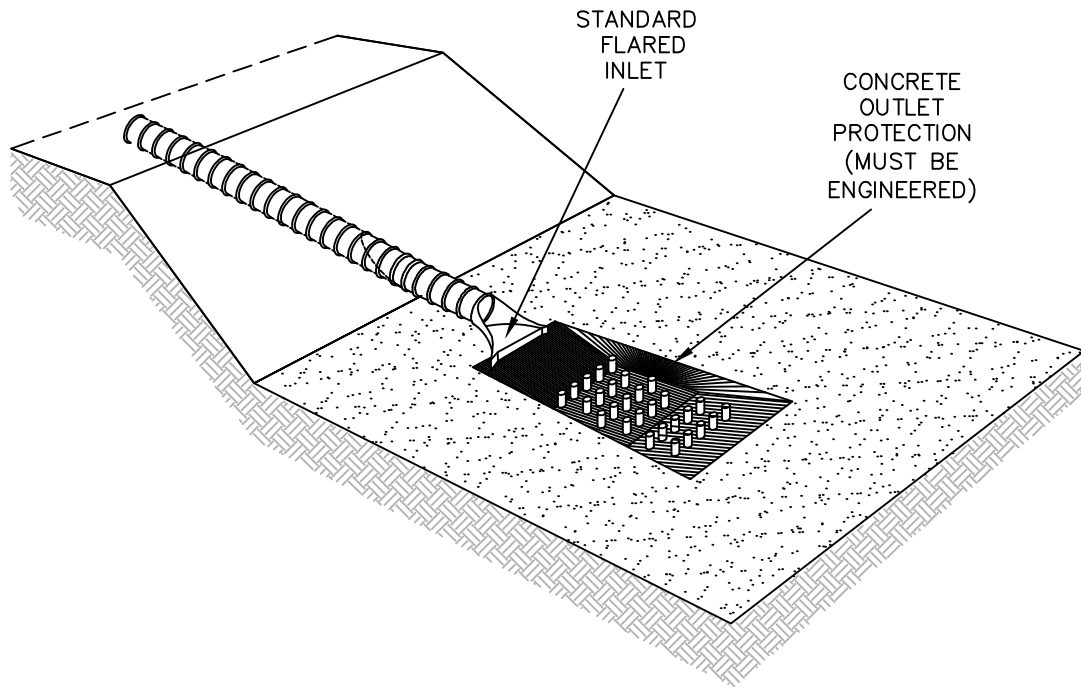

ENERGY DISSIPATER  
(TECHNIQUE VARIES)

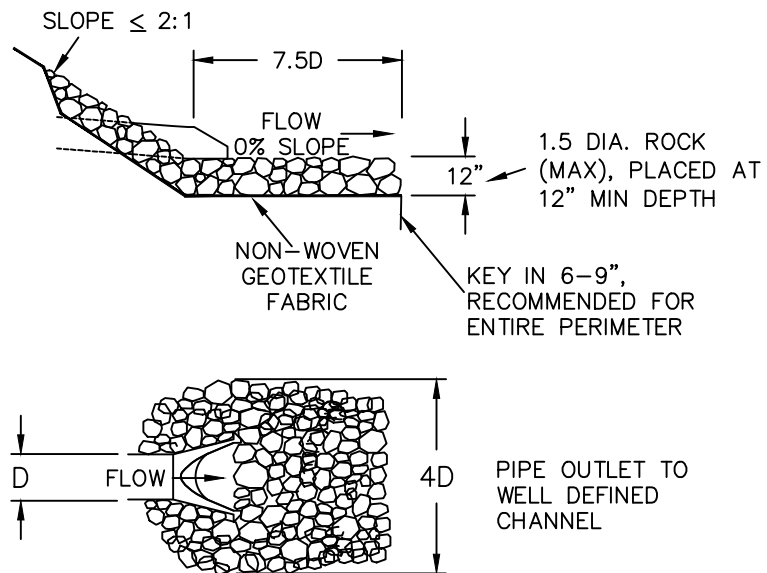

ROCK RIP-RAP  
DISSIPATER

NOTE: RIPRAP SHOULD BE SIZED FOR THE EXPECTED MAXIMUM ENERGY

### APPLICATIONS

1. USED AT OUTLETS OF CULVERTS, DRAINAGE PIPES, OR OTHER CONDUITS WHEN FLOW VELOCITIES HAVE THE POTENTIAL TO SCOUR AT OUTLET POINT.
2. TO PROTECT AGAINST SCOURING AT A CULVERT END SECTION AND TO REDUCE DISCHARGE FLOW VELOCITIES TO NON-EROSIVE LEVELS.
3. WHERE THE ENERGY TRANSMITTED FROM A CONCENTRATED FLOW OF SURFACE RUNOFF IS SUFFICIENT TO ERODE RECEIVING AREA AND/OR WATERCOURSE.

### DESIGN

1. UNLESS OTHERWISE SPECIFIED, DISSIPATER SHOULD BE SUFFICIENT TO HANDLE PEAK RUNOFF FROM A 10-YEAR, 24 HOUR RAINFALL EVENT.
2. DISSIPATER APRON SHOULD BE SIZED FOR OUTFLOW RATE AND EXPECTED TAILWATER LEVEL (IF APPLICABLE).

### DESIGN (CONT)

3. DISSIPATER APRON SHOULD BE SIZED FOR OUTFLOW RATE AND EXPECTED TAILWATER LEVEL (IF APPLICABLE).
4. DISSIPATER TO BE CONSTRUCTED WITH ALIGNMENT SQUARE TO RECEIVING WATERCOURSE, WITH DISSIPATER KEPT STRAIGHT THROUGHOUT ENTIRE LENGTH.
5. FOR RIPRAP LINED DISSIPATERS, RIP-RAP SHOULD BE PLACED ON NON-WOVEN GEOTEXTILE FABRIC TOED IN A MINIMUM OF 6-9" ALONG THE ENTIRE PERIMETER.
6. DEPTH OF ROCK SHOULD BE 1.5 TIMES MAXIMUM ROCK DIAMETER, PLACED ON NON-WOVEN GEOTEXTILE FABRIC.
7. CONCRETE DISSIPATER TO BE INSTALLED SQUARE WITH RECEIVING WATERCOURSE, OR PER MANUFACTURER DIRECTIONS.

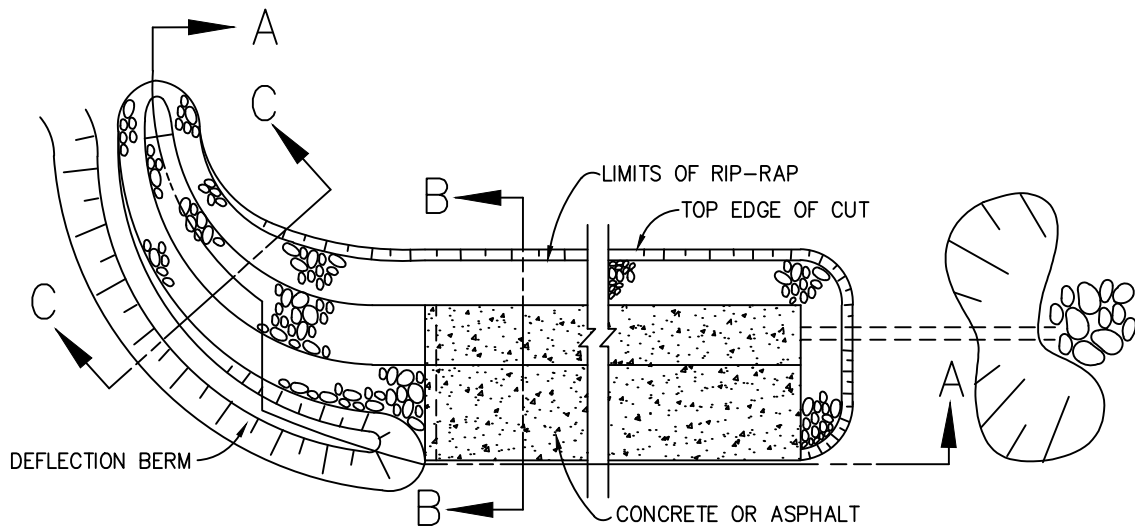

PLAN VIEW

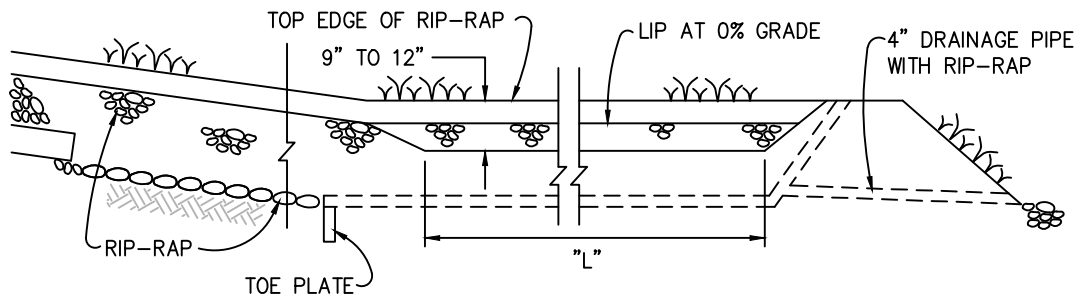

SECTION A-A

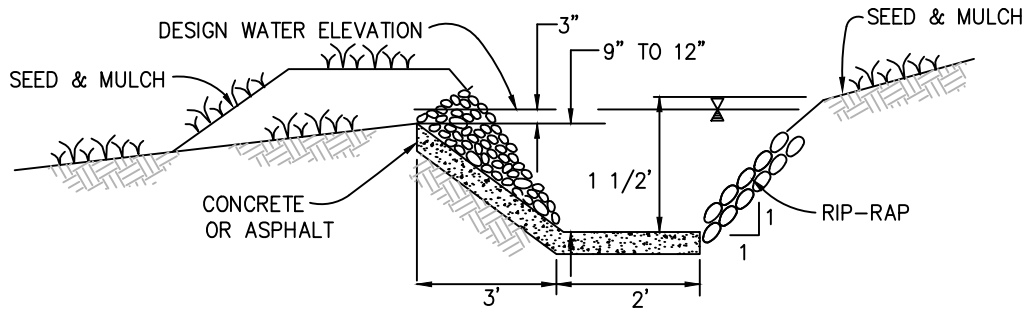

SECTION B-B

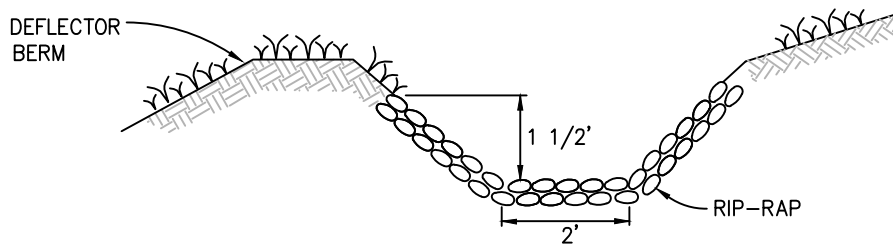

SECTION C-C

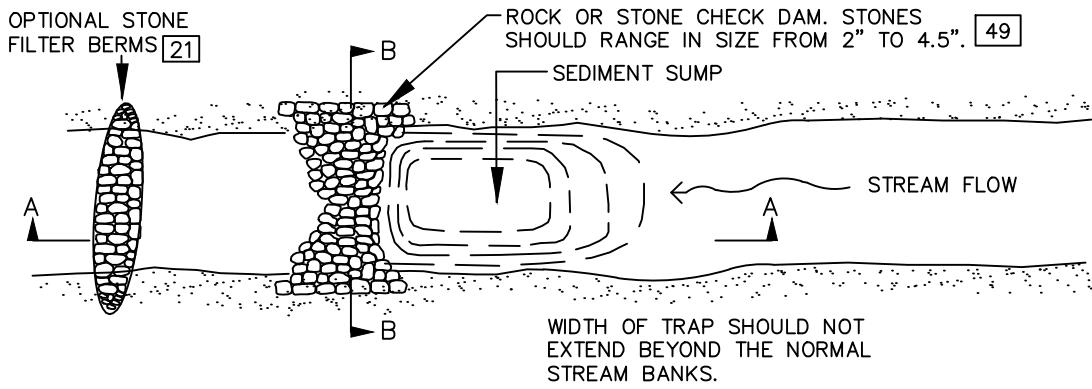

PLAN VIEW

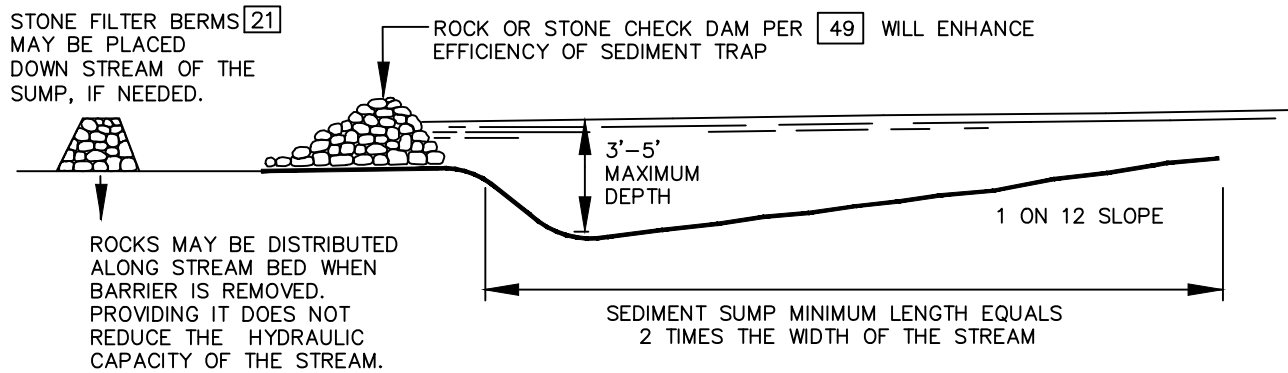

SECTION A - A

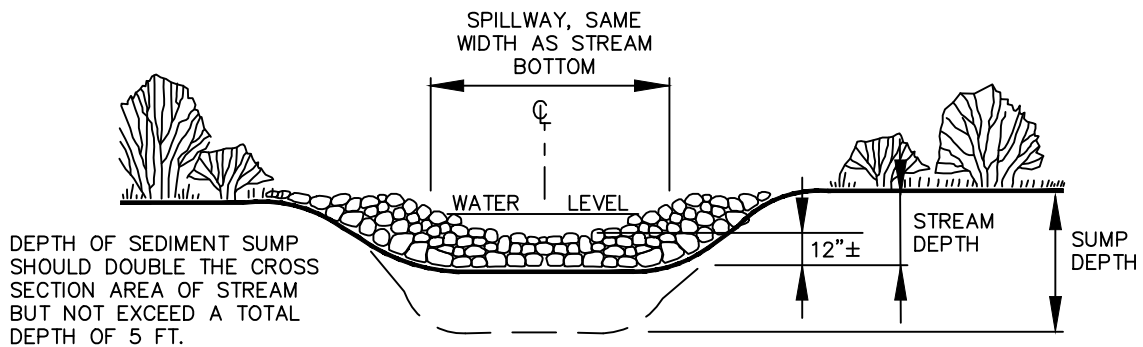

SECTION B - B

APPLICATION

1. FLOWING STREAMS.

DESIGN

1. TRAP DESIGN FOR APPROXIMATELY 170 FT<sup>3</sup> OF SEDIMENT.
2. REMOVED SEDIMENT AND RESTORE ORIGINAL CAPACITY WHEN SUMP IS 50% FULL.
3. STONE SHALL BE MAINTAINED AND REPAIRED WHEN DAMAGE OR DISPLACED.
4. WARNING! THIS DEVICE MAY CAUSE FLOODING OF ADJACENT PROPERTY.

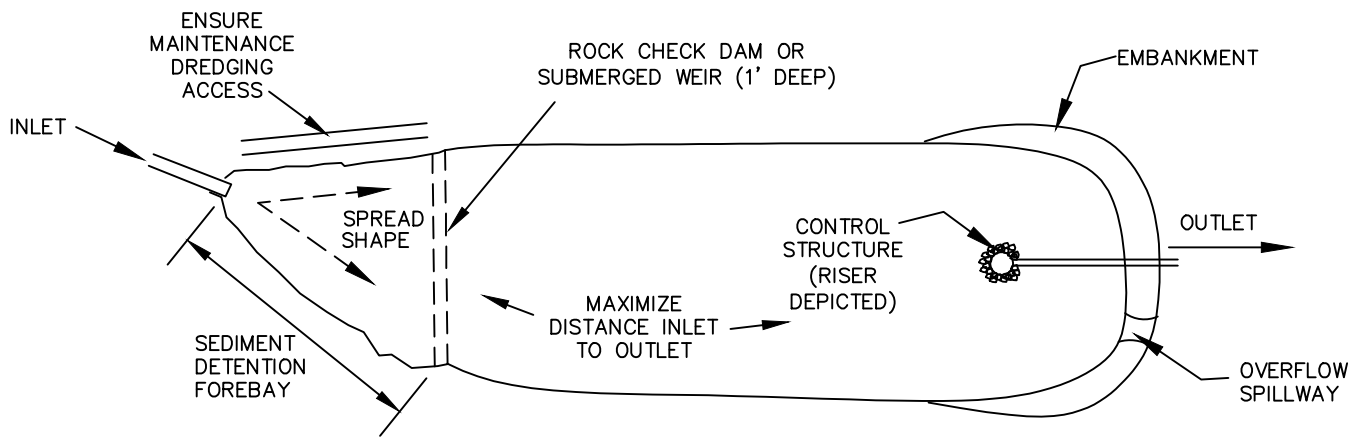

PLAN VIEW

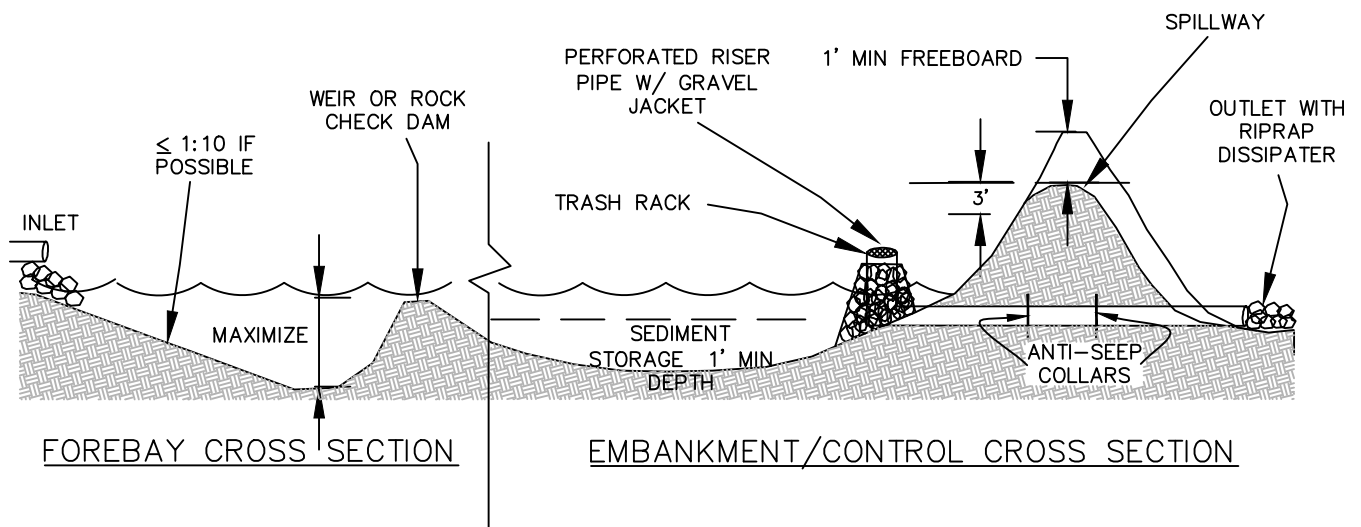

FOREBAY CROSS SECTION

EMBANKMENT/CONTROL CROSS SECTION

APPLICATIONS

1. WHEN SITE RUNOFF IS SEDIMENT-LADEN AND/OR RUNOFF RELEASE RATE IS REQUIRED.
2. TO DETAIN RUNOFF SUFFICIENTLY TO ALLOW EXCESSIVE SEDIMENT TO SETTLE OUT BEFORE STORMWATER LEAVES CONSTRUCTION SITE.
3. AT THE OUTLET OF ANY DISTURBED AREA OR AT THE ULTIMATE SITE OUTLET.
4. SHOULD BE USED IN ASSOCIATION WITH DIKES, TEMPORARY CHANNELS, AND PIPES TO DIVERT STORMWATER FROM THE DISTURBED AREAS INTO THE BASIN.
5. MAY BE COMBINED WITH PERMANENT DETENTION BASIN.

DESIGN

1. BASIN TO BE DESIGNED TO ENSURE ADEQUATE STORAGE VOLUME FROM THE CONTRIBUTING DRAINAGE AREA.
2. BASINS SHOULD BE CONSTRUCTED BEFORE CLEARING AND GRADING WORK BEGINS.
3. BASINS SHOULD BE LOCATED AT THE STORMWATER OUTLET FOR THE SITE AND MULTIPLE BASINS MAY BE LOCATED THROUGHOUT THE SITE.

DESIGN (CONT)

4. BASIN LOCATION SHOULD ENSURE SUITABLE ACCESS FOR MAINTENANCE AND CLEANOUT.
5. DO NOT LOCATE IN A STREAM.
6. ALL BASIN SITES SHOULD BE LOCATED WHERE EMBANKMENT FAILURE WILL NOT COMPROMISE SAFETY OR RESULT IN PROPERTY DAMAGE.
7. THE BASIN VOLUME SHOULD BE DESIGNED TO HANDLE THE VOLUME OF STORMWATER EXPECTED FROM THE DISTURBED ACREAGE FOR A MINIMUM 10-YEAR STORM EVENT.
8. THE BASIN VOLUME CONSISTS OF TWO ZONES
  - A SEDIMENT STORAGE ZONE TO A 1' MINIMUM DEPTH.
  - A SETTLING ZONE AT LEAST 2 FEET DEEP.
9. DESIGN SHOULD CONTAIN SUFFICIENT CAPACITY TO DETAIN RUNOFF FOR 24-48 HOURS, MAXIMIZING SEDIMENT SETTLEMENT POTENTIAL.
10. LENGTH TO WIDTH RATIO SHOULD BE GREATER THAN 4:1 TO ALLOW FOR SUFFICIENT SETTLEMENT TIME.
11. UTILIZE A WELL ANCHORED RISER PIPE WITH ANTI-SEEP COLLARS AS THE PRINCIPAL OUTLET, ALONG WITH AN EMERGENCY OVERFLOW SPILLWAY FOR MAJOR EVENTS.
12. TYPICALLY, PERMANENT BASINS ARE USED FOR DRAINAGE OF 5 ACRES OR MORE.

THIS PAGE INTENTIONALLY LEFT BLANK

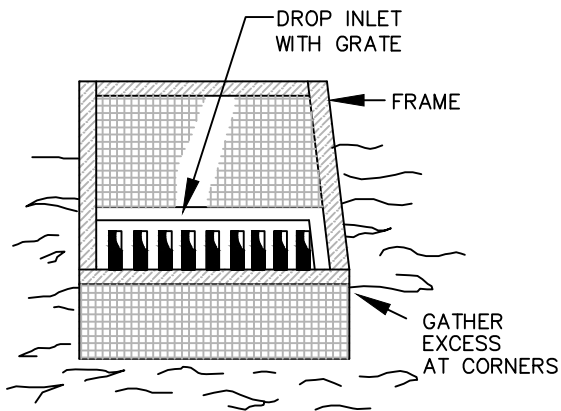
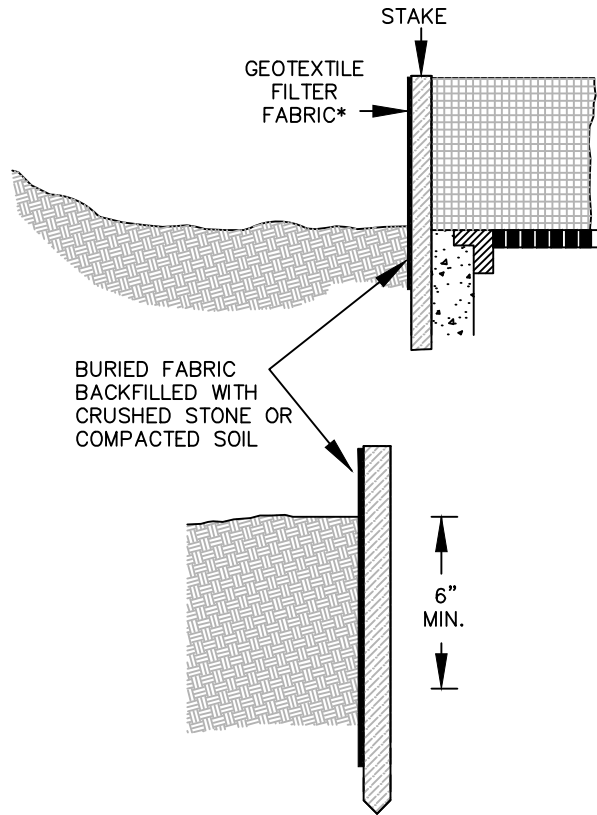
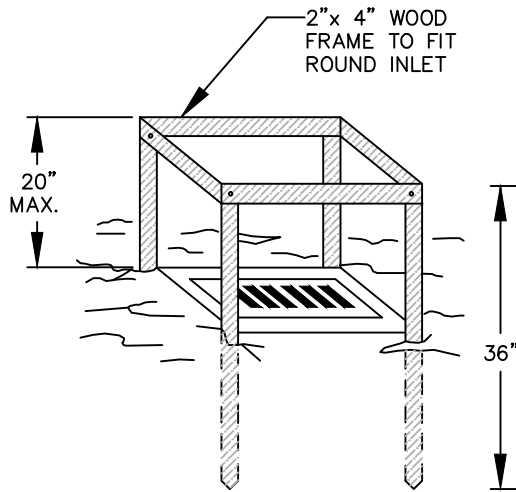

### APPLICATIONS

1. INLETS WITH DRAINAGE OF 1 ACRE OR LESS AND SLOPES LESS THEN 5%.
2. SERVICE, CLEAN AND REPAIR AFTER EACH STORM EVENT.

### \* NOTE \*

DO NOT USE SILT FENCE IN LIEU OF FILTER FABRIC FOR THIS APPLICATION.

### DESIGN

1. FILTER BAGS MAY BE PLACED IN THE MANHOLE TO INCREASE THE EFFECTIVENESS OF THIS DEVICE.
2. IN SOME CASES FILTER BAGS IN THE MANHOLE MAY BE USED ALONE.
3. WARNING! THIS DEVICE MAY CAUSE FLOODING OF ADJACENT PROPERTY!
4. TOP OF FRAME (PONDING HEIGHTS) MUST BE LOWER THAN GROUND ELEVATION DOWN STREAM TO PREVENT BYPASSING THE INLET. A TEMPORARY DIKE MAY BE NECESSARY DOWN SLOPE OF THE STRUCTURE.

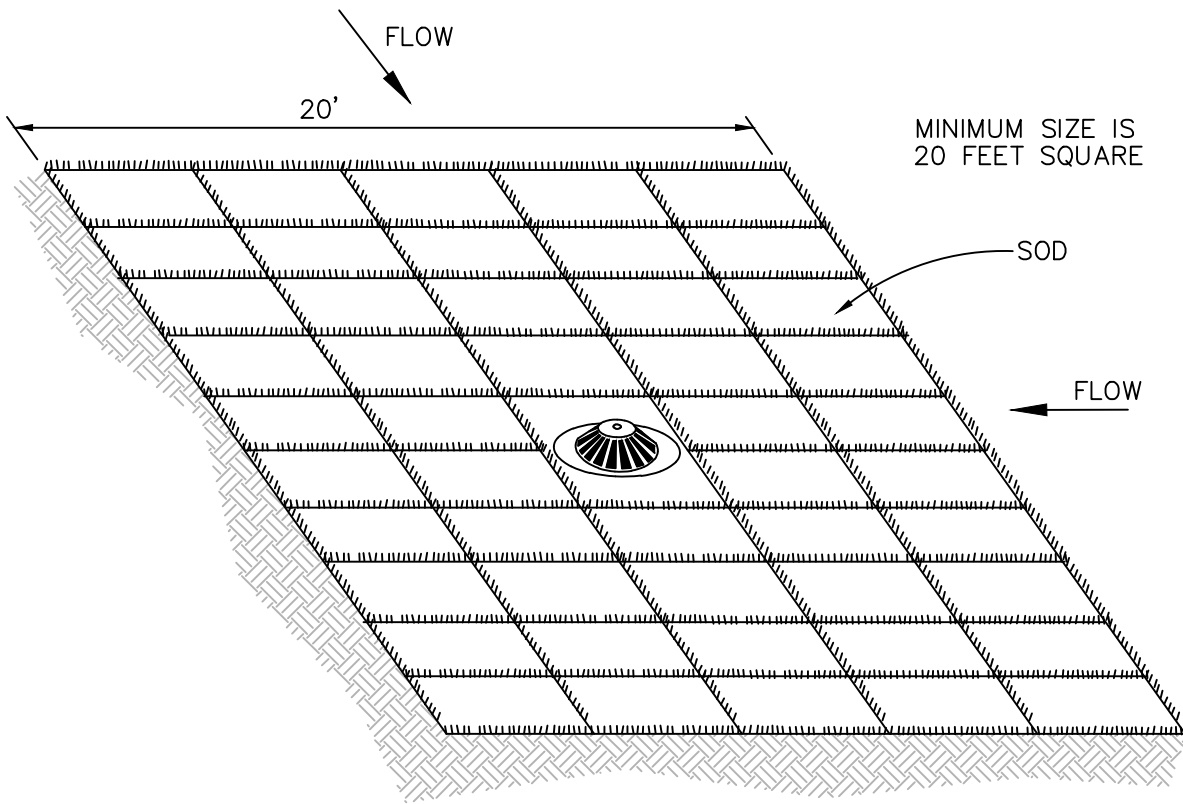

ISOMETRIC VIEW

APPLICATIONS

1. SOD INLET FILTERS ARE INSTALLED TO SLOW THE FLOW OF WATER INTO AN INLET OR CATCH BASIN AND TO FILTER OUT APPRECIABLE AMOUNTS OF SEDIMENT IN THE PROCESS.
2. SOD INLET FILTERS SHOULD ONLY BE USED TO HANDLE LIGHT CONCENTRATIONS OF SEDIMENTS. THEY ARE BEST USED AFTER FINAL GRADING IS COMPLETE AND DURING THE ESTABLISHMENT OF A VEGETATIVE COVER.

DESIGN

1. SOD INLET FILTER ARE PADS OF SOD PLACED AROUND A STORM DRAIN INLET OR CATCH BASIN.



THIS PAGE INTENTIONALLY LEFT BLANK

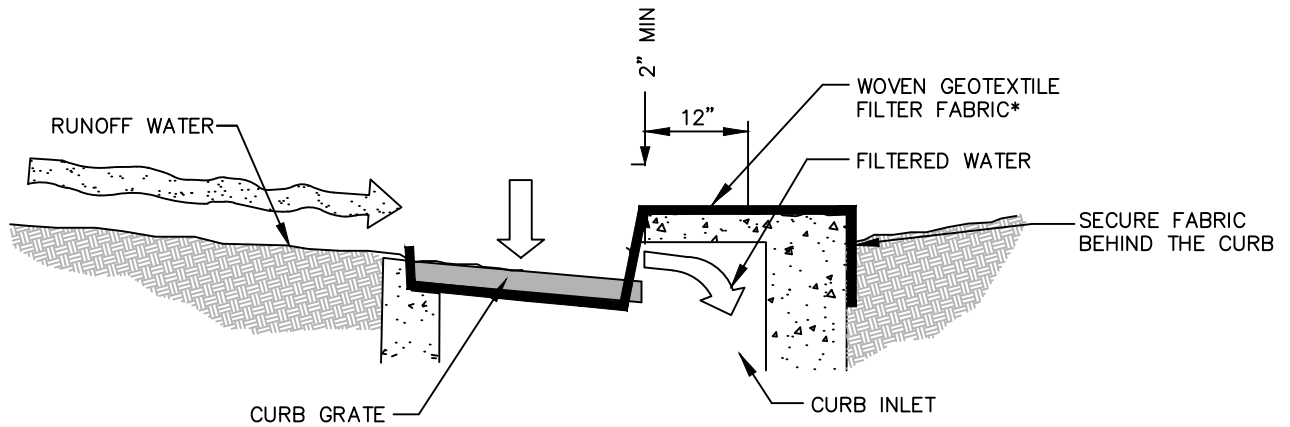
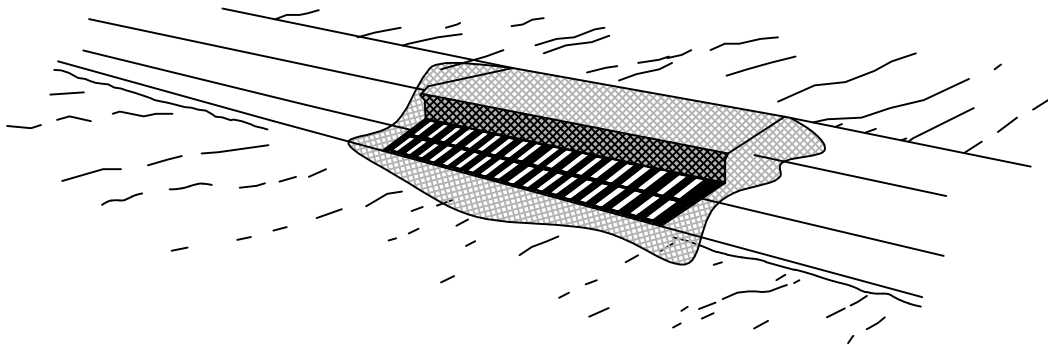

APPLICATION

1. INLETS AT CURB OPENINGS.

\* NOTE \*

DO NOT USE SILT FENCE IN LIEU OF FILTER FABRIC FOR THIS APPLICATION.

DESIGN

1. FILTER BAGS MAY BE PLACED IN THE CATCH BASIN AS AN ALTERNATE.
2. WARNING! THIS DEVICE MAY CAUSE FLOODING OF ADJACENT PROPERTIES.
3. SERVICE CLEAN AND REPAIR AFTER EACH STORM EVENT.

FABRIC FILTER  
CURB INLET PROTECTION

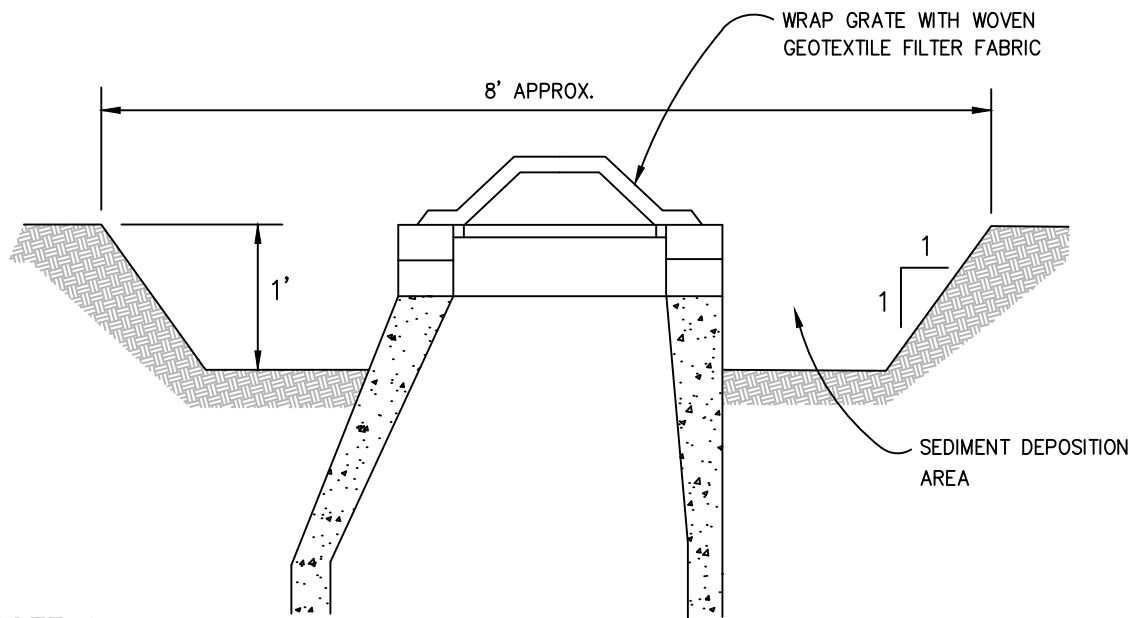
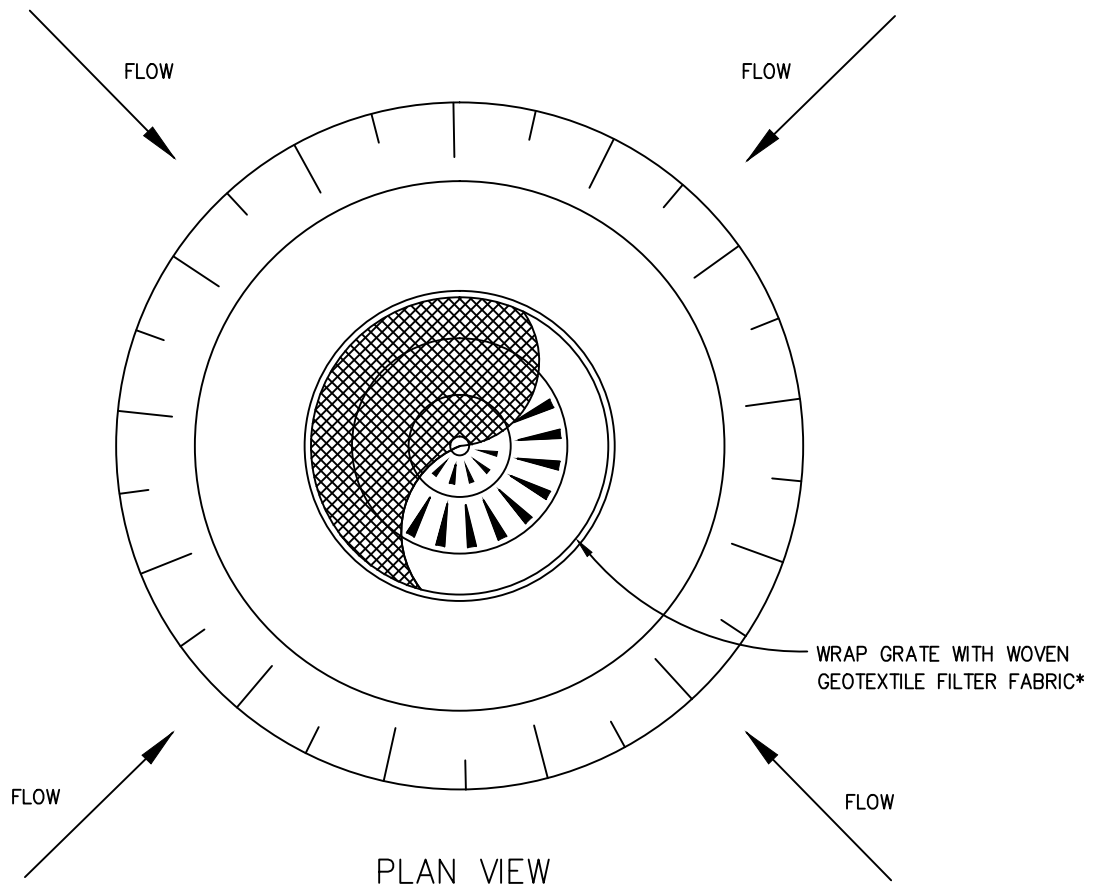

\* NOTE \*

DO NOT USE SILT OR ANY NON-WOVEN MATERIAL FENCE IN LIEU OF FILTER FABRIC FOR THIS APPLICATION.

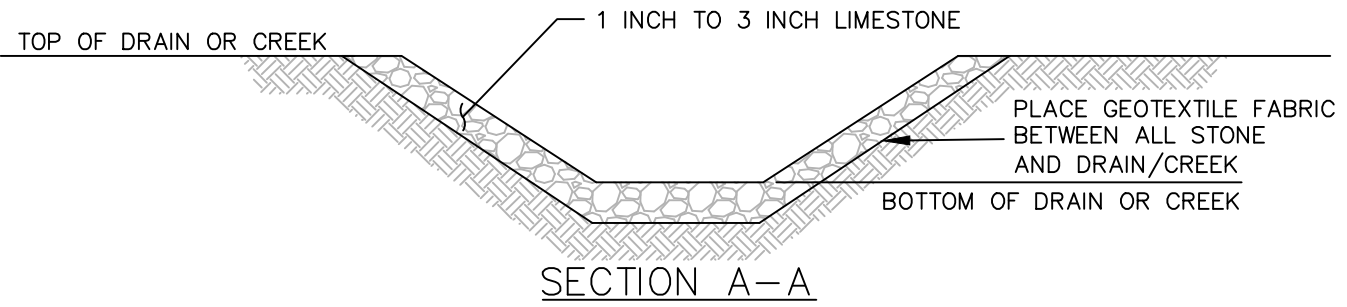
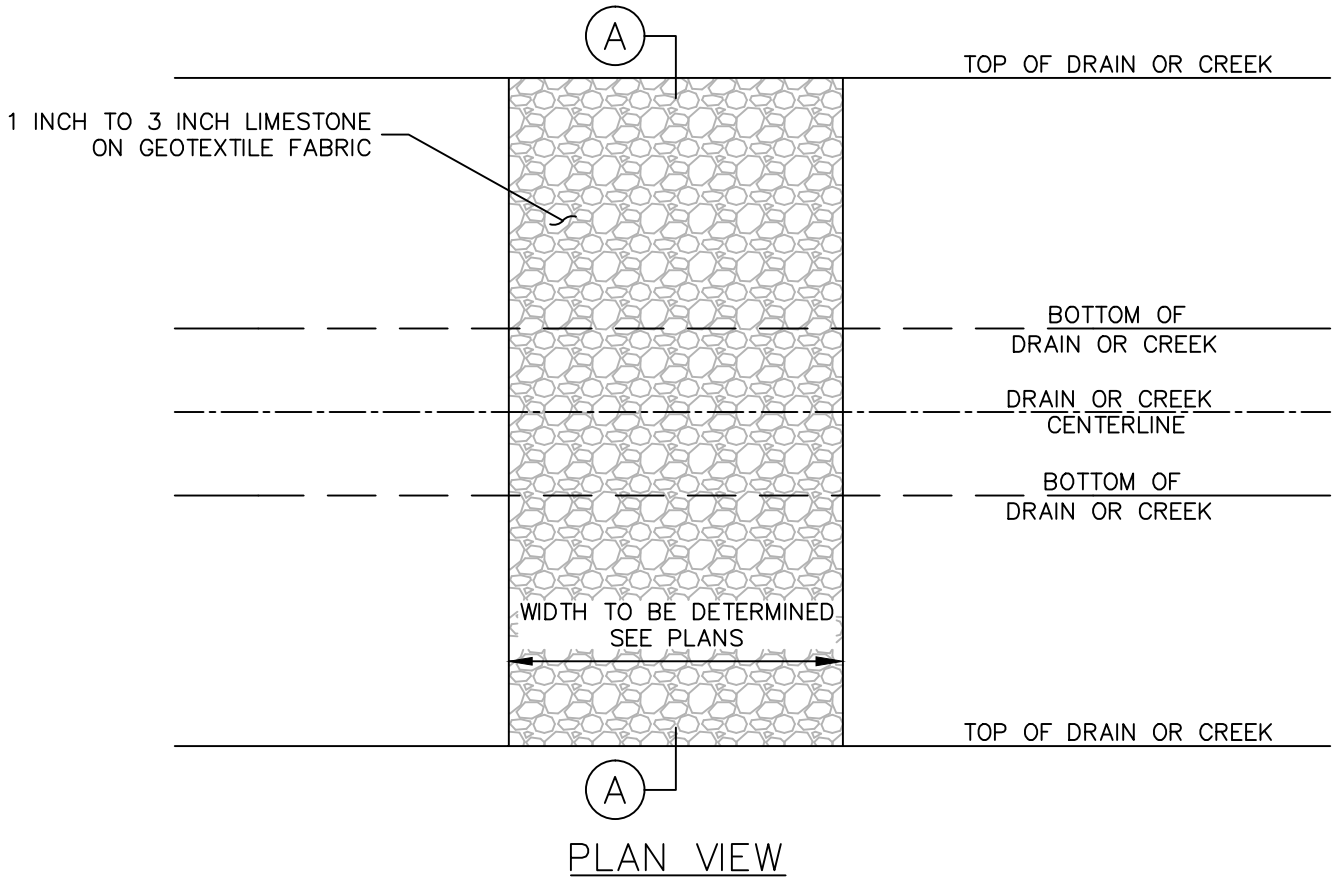

NOTES:

1. FORDING, DRIVING OR MOVING CONSTRUCTION EQUIPMENT OR VEHICLES THROUGH THE BED OF A DRAIN OR CREEK IS NOT PERMITTED AT ANY TIME.
2. TEMPORARY CROSSINGS SHALL BE REMOVED WITHIN TWO WEEKS OF THE WORK REACHING THE NEXT CROSS ROAD.
3. THE BOTTOM OR INVERT ELEVATION OF THE DRAIN/CREEK SHALL BE MAINTAINED AFTER TEMPORARY STONE PLACEMENT.
4. ALL STONE USED FOR THE TEMPORARY CROSSING SHALL BE REMOVED FROM THE DRAIN/CREEK.
5. SEED AND HIGH VELOCITY MULCH BLANKETS SHALL BE USED TO RESTORE DRAIN/CREEK BANKS. 3 TO 6 INCH SIZE STONE SHALL BE USED TO RESTORE THE BOTTOM OF THE DRAIN/CREEK.
6. CONTRACTOR ASSUMES ALL RESPONSIBILITY FOR DAMAGE DUE TO WET WEATHER FLOWS.

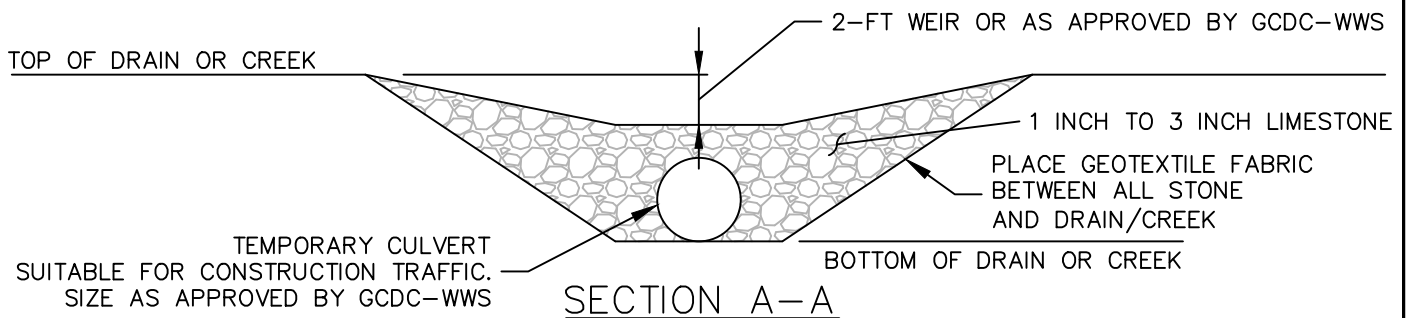
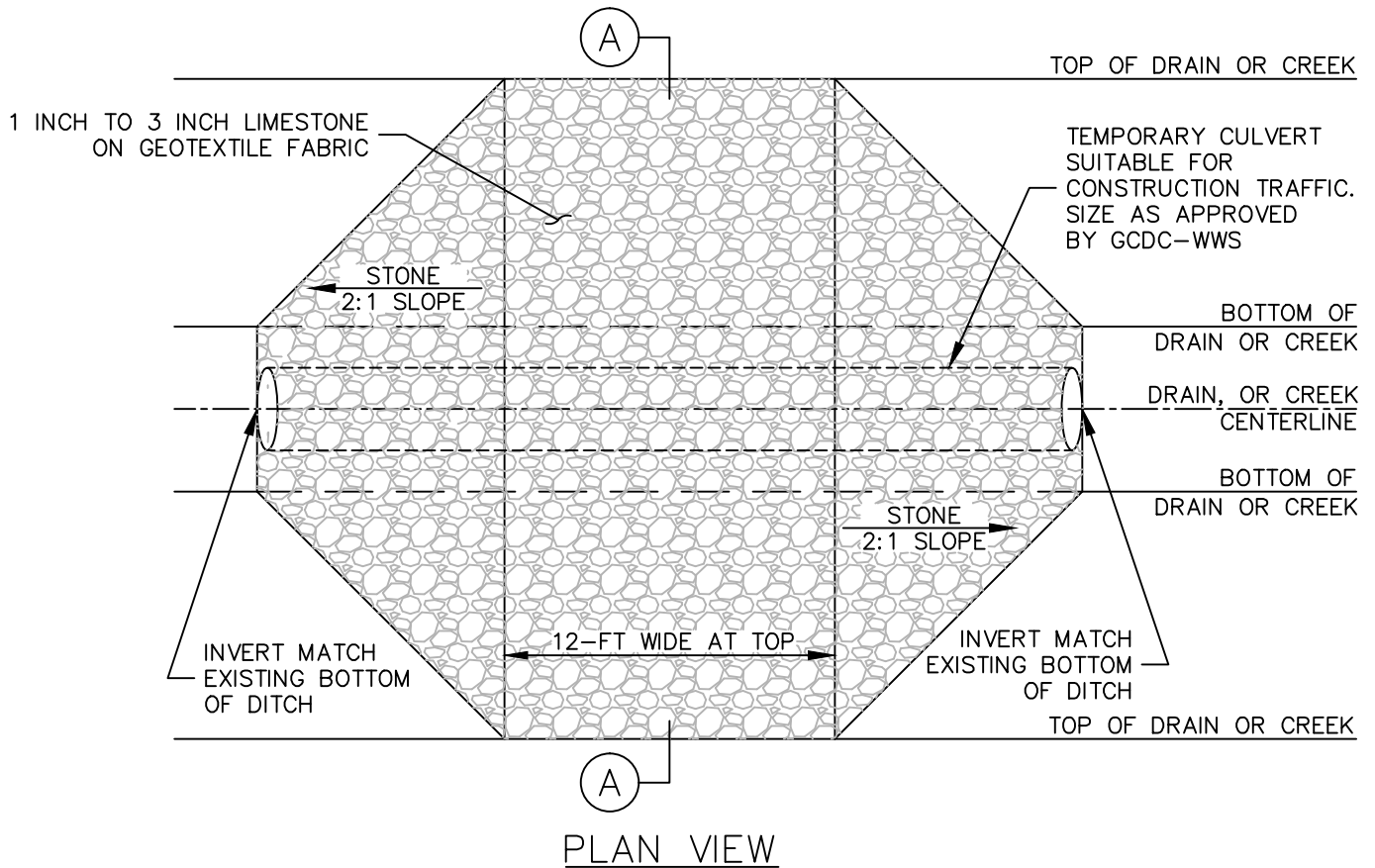

**NOTES:**

1. FORDING, DRIVING OR MOVING CONSTRUCTION EQUIPMENT OR VEHICLES THROUGH THE BED OF A DRAIN OR CREEK IS NOT PERMITTED AT ANY TIME.
2. TEMPORARY CROSSINGS SHALL BE REMOVED WITHIN TWO WEEKS OF THE WORK REACHING THE NEXT CROSS ROAD.
3. ALL STONE USED FOR THE TEMPORARY CROSSING SHALL BE REMOVED FROM THE DRAIN/CREEK.
4. SEED AND HIGH VELOCITY MULCH BLANKETS SHALL BE USED TO RESTORE DRAIN/CREEK BANKS. 3 TO 6 INCH SIZE STONE SHALL BE USED TO RESTORE THE BOTTOM OF THE DRAIN/CREEK.
5. CONTRACTOR ASSUMES ALL RESPONSIBILITY FOR DAMAGE DUE TO WET WEATHER FLOWS.

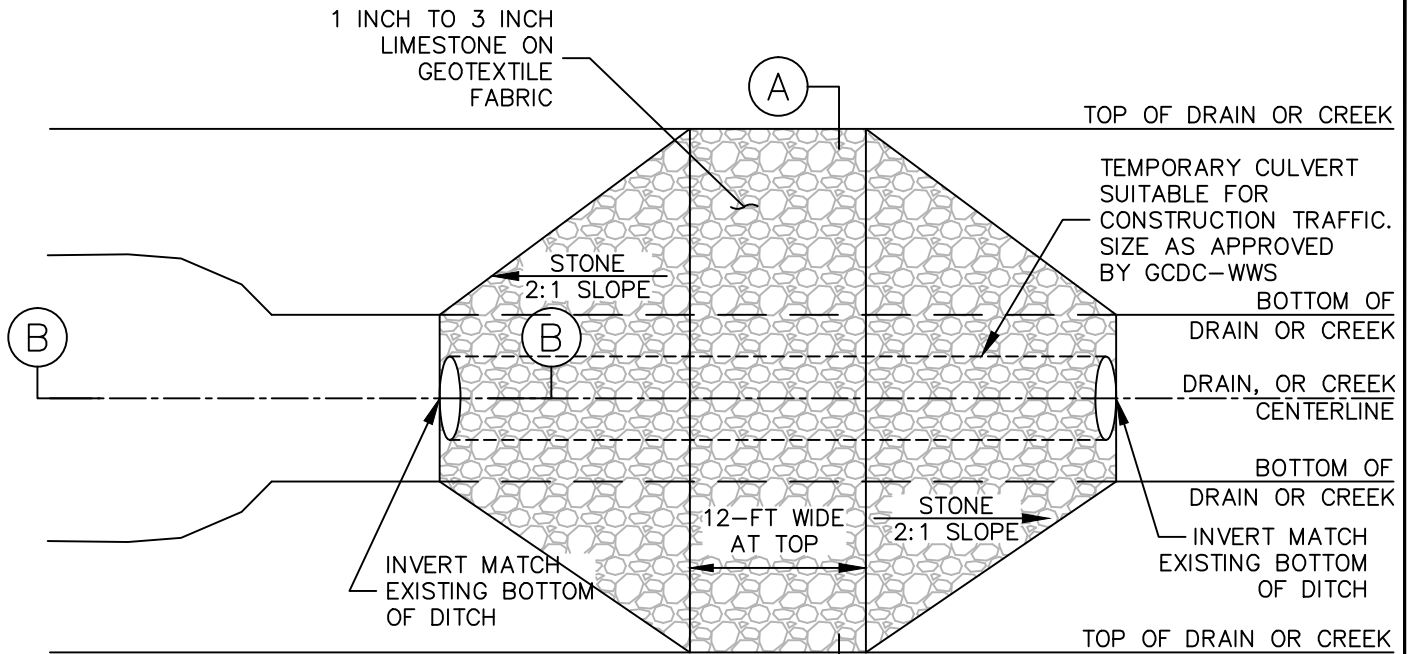

PLAN VIEW

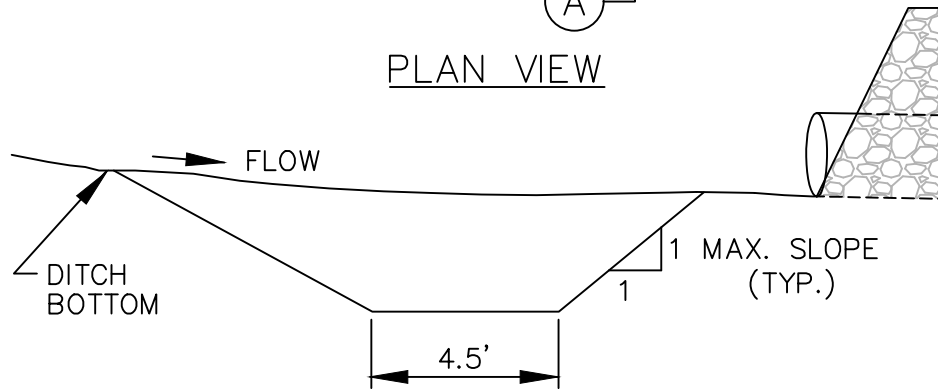

SECTION B-B

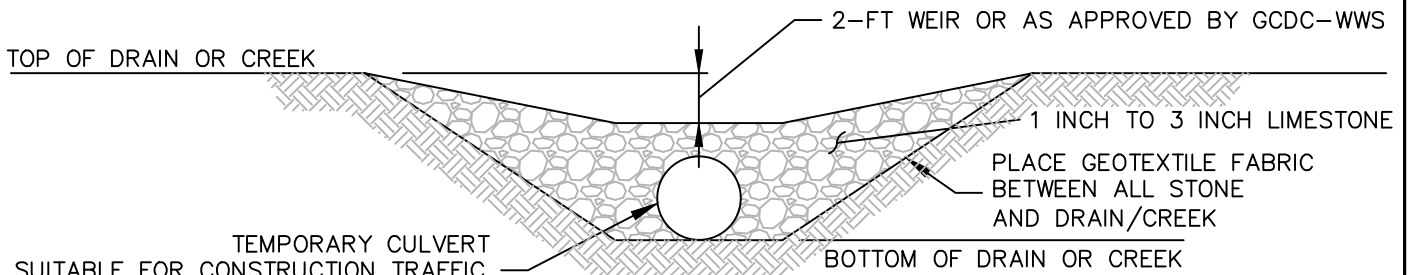

SECTION A-A

**NOTES:**

1. FORDING, DRIVING OR MOVING CONSTRUCTION EQUIPMENT OR VEHICLES THROUGH THE BED OF A DRAIN OR CREEK IS NOT PERMITTED AT ANY TIME.
2. TEMPORARY CROSSINGS SHALL BE REMOVED WITHIN TWO WEEKS OF THE WORK REACHING THE NEXT CROSS ROAD.
3. ALL STONE USED FOR THE TEMPORARY CROSSING SHALL BE REMOVED FROM THE DRAIN/CREEK.
4. SEED AND HIGH VELOCITY MULCH BLANKETS SHALL BE USED TO RESTORE DRAIN/CREEK BANKS. 3 TO 6 INCH SIZE STONE SHALL BE USED TO RESTORE THE BOTTOM OF THE DRAIN/CREEK.
5. CONTRACTOR ASSUMES ALL RESPONSIBILITY FOR DAMAGE DUE TO WET WEATHER FLOWS.

THIS PAGE INTENTIONALLY LEFT BLANK

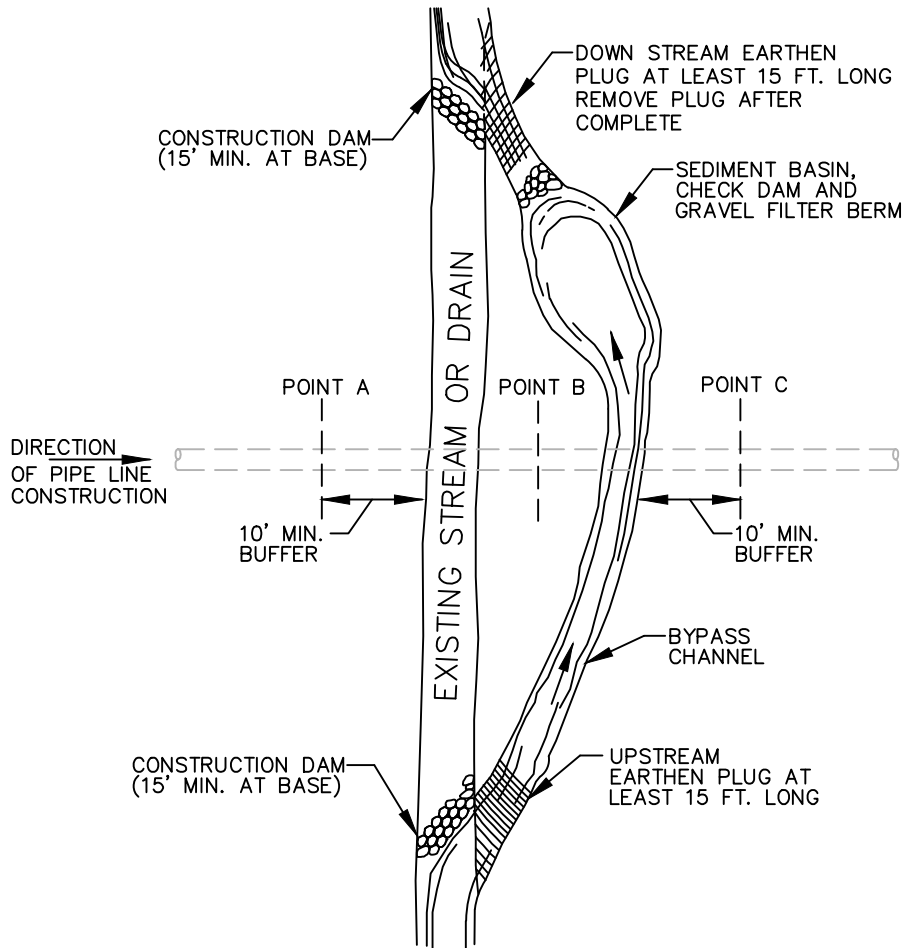

### APPLICATIONS

1. STREAM CROSSING THAT NEEDS A DRY CONSTRUCTION SITE.

### DESIGN

1. EXCAVATE BYPASS CHANNEL BEFORE PIPE LINE CONSTRUCTION REACHES POINT A.
2. INSTALL STREAM SEDIMENT BASIN.
3. REMOVE DOWNSTREAM PLUG AND STABILIZE CHANNEL DOWNSTREAM OF SEDIMENT BASIN WITH GEOTEXTILE FABRIC OR MDOT RIPRAP TO PREVENT EROSION. ALTERNATIVE IS TO LOCATE SEDIMENT BASIN ON DOWNSTREAM CHANNEL.
4. REMOVE UPSTREAM PLUG.
5. INSTALL UPSTREAM CONSTRUCTION DAM.

### DESIGN (CONT)

6. INSTALL DOWN STREAM CONSTRUCTION DAM.
7. INSTALL PIPELINE FROM POINT A TO POINT B AND STABILIZE DISTURBED STREAM CHANNEL AND BANKS WITH MULCH BLANKET AND/OR RIPRAP.
8. REMOVE DOWN STREAM CONSTRUCTION DAM.
9. REMOVE UP STREAM CONSTRUCTION DAM.
10. INSTALL EARTHEN PLUG AT UPSTREAM AND DOWN STREAM ENDS OF BYPASS CHANNEL STABILIZE WITH RIPRAP AND/OR MULCH BLANKET.
11. BACKFILL BYPASS CHANNEL.
12. STABILIZE AND RESTORE ALL DISTURBED AREAS.



THIS PAGE INTENTIONALLY LEFT BLANK

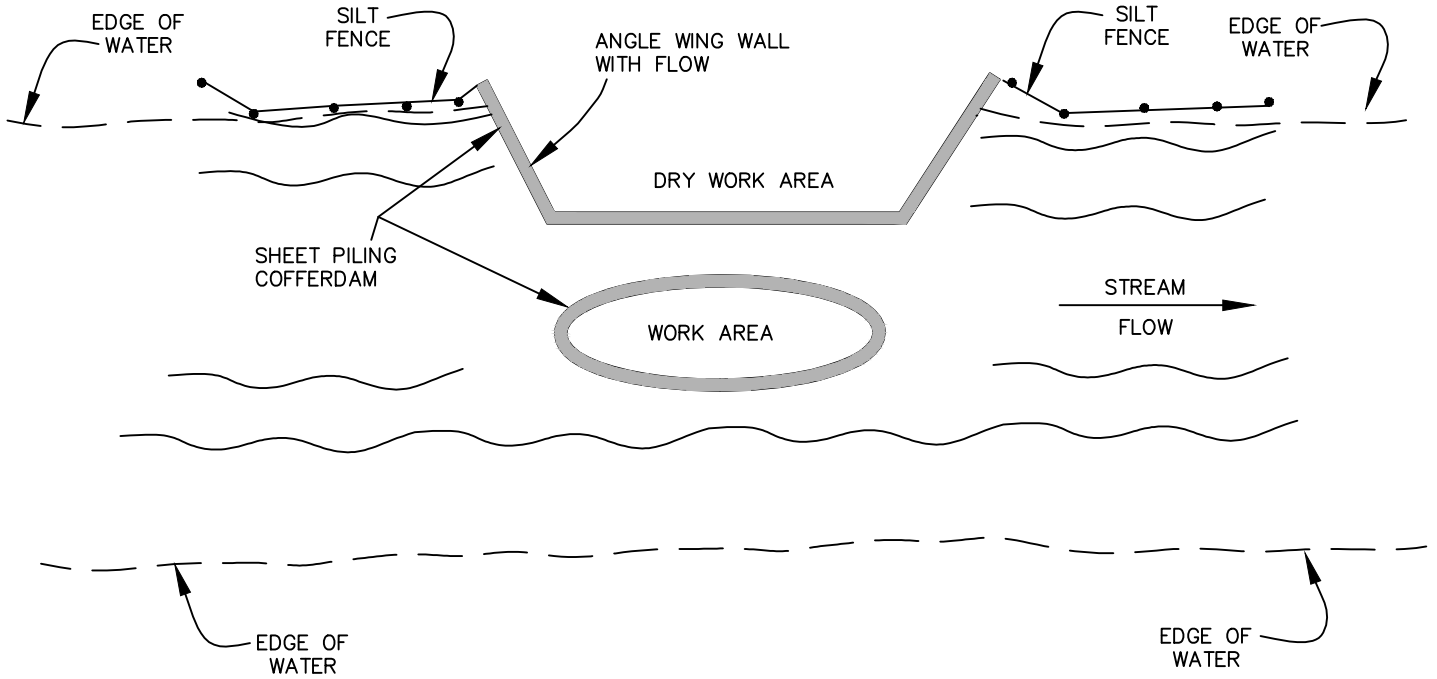

SHEET PILING COFFERDAM – PLAN

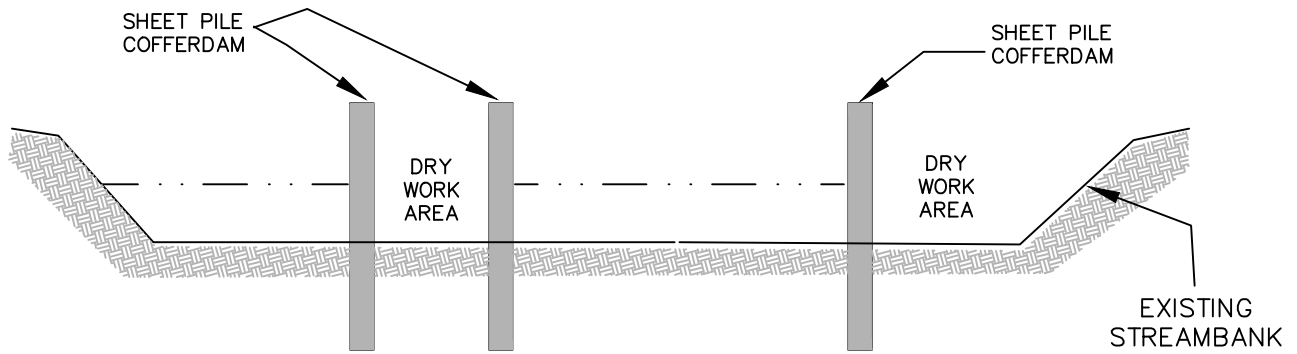

COFFERDAM CROSS-SECTION

THIS PAGE INTENTIONALLY LEFT BLANK

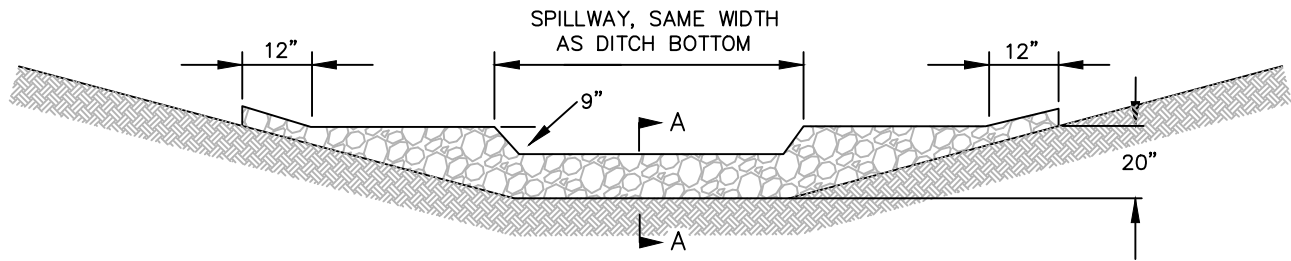

SECTION A - A

APPLICATION

1. ACROSS DITCH LINES AND LOW CONCENTRATED FLOW AREAS.

DESIGN

1. CHECK DAM STONES:  
2" TO 4" SIZE FOR DITCH GRADE LESS THAN 2%.  
3" TO 8" SIZE FOR DITCH GRADES 2% OR GREATER.
2. APPROXIMATELY 90% OF STONE SIZE SHALL BE BETWEEN THE RANGES INDICATED. NO STONES GREATER THAN 8" SHALL BE ALLOWED.
3. SEDIMENT TRAPS MAY BE INSTALLED IMMEDIATELY UP SLOPE TO INCREASE ABILITY TO COLLECT SEDIMENT.
4. IF MULTIPLE CHECK DAMS ARE USED, THE GENERAL GUIDE TO SPACING IS THAT THE CREST OF THE DOWN SLOPE CHECK DAM SHOULD EQUAL THE ELEVATION OF THE TOE OF THE UP SLOPE CHECK DAM.

DESIGN (CONT)

5. CHECK DAMS SHALL BE REMOVED IN THEIR ENTIRETY WHEN THE SOIL IS ADEQUATELY STABILIZED. ANY DAMAGE CAUSED DURING REMOVAL MUST BE REPAIRED. IF DIRECTED BY THE ENGINEER/OWNER, CHECK DAMS MAY BE SPREAD OUT ON THE DITCH LOCATION PROVIDING THAT THE DITCH BOTTOM ELEVATION IS NOT INCREASED BY MORE THAN 6".
6. STONE SHALL BE MONITORED AND REPAIRED WHEN DAMAGED OR DISPLACED.
7. ALTERNATE: A MANUFACTURED BERM CAN INSTALLED IF APPROVED BY WWS. SPACING TO BE PER MANUFACTURER'S RECOMMENDATION.
8. WARNING THIS DEVICE MAY CAUSE FLOODING OF ADJACENT PROPERTY.

THIS PAGE INTENTIONALLY LEFT BLANK

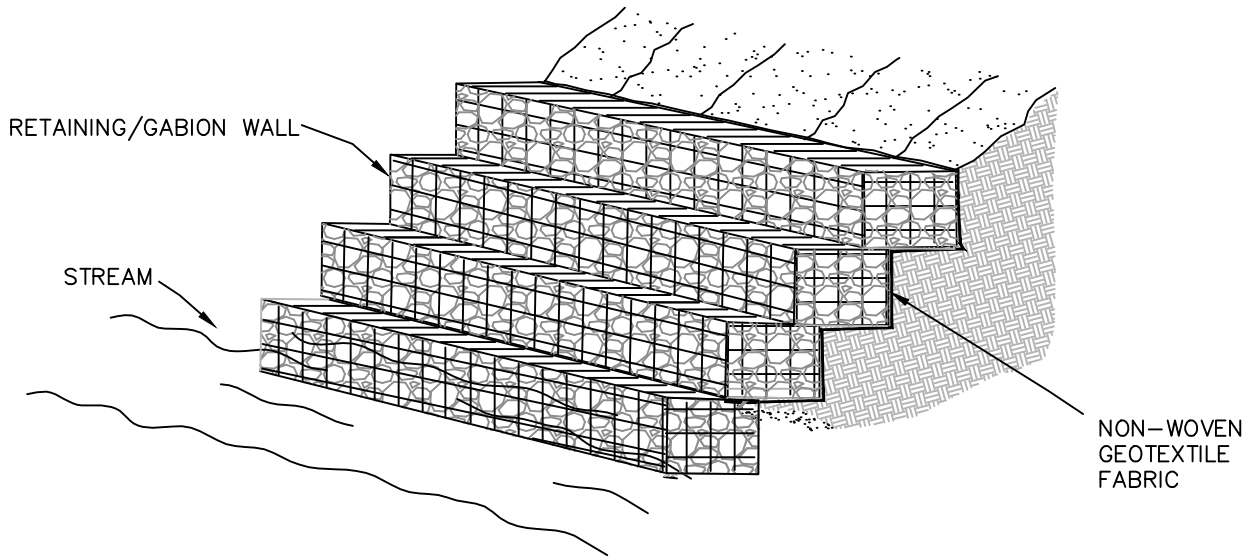

OBLIQUE VIEW

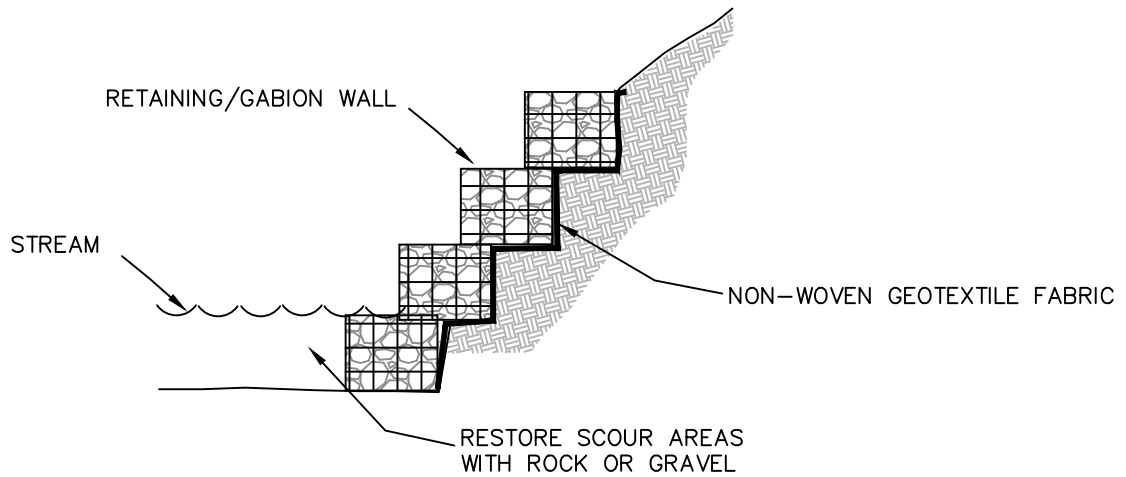

CROSS SECTION

APPLICATIONS

1. WHEN FLOW VELOCITIES ARE RESULTING IN MAJOR BANK OR SLOPE FAILURE.
2. TO STOP AND THEN MINIMIZE SOIL EROSION ON STREAM BANKS.
3. ON EXISTING STREAM BANKS TO ADDRESS OR PREVENT SURFACE VELOCITY CAUSED EROSION.
4. ON SLOPES WHICH ARE TOO STEEP FOR STANDARD RIP-RAP (GREATER THAN 1:2).

DESIGN

1. REMOVE LOOSE MATERIAL TO PROVIDE A FIRM FOUNDATION FOR GABION BASKETS.
2. WIRE MESH WHICH MAKES UP THE GABION BASKET SHOULD BE NO SMALLER THAN 12 GAUGE. MESH SIZE WILL VARY ON ROCK SIZE USED TO FILL THE BASKET. 9 GAUGE WIRE SHOULD BE USED FOR ALL TIES AND LACING.

DESIGN (CONT)

3. PLACE NON-WOVEN GEOTEXTILE FABRIC ON BANK TO PREVENT LOSS OF FINE GRAINED SOILS INTO GABIONS. SECURE ENDS AT LEAST EVERY 8" ALONG SEAMS. A MINIMUM OF 2 TIES SHOULD BE MADE BETWEEN GABIONS FOR EVERY SQUARE FOOT OF CONTACT AREA.
4. FILL VOIDS BETWEEN EXCAVATION LINE OR BANK WITH GRAVEL AND COBBLE FILL.
5. GABION INSTALLATION TO BEGIN AND END AT STABLE BANK POINTS.
6. PROVIDE LOOSE ROCK RIPRAP TRANSITION ZONES IF NECESSARY.
7. INSTALL ONLY SINGLE ROW OF GABIONS FOR LOW BANK (3'±) PROTECTION. UTILIZE MULTIPLE ROWS FASTENED TOGETHER FOR HIGH BANK PROTECTION.

THIS PAGE INTENTIONALLY LEFT BLANK

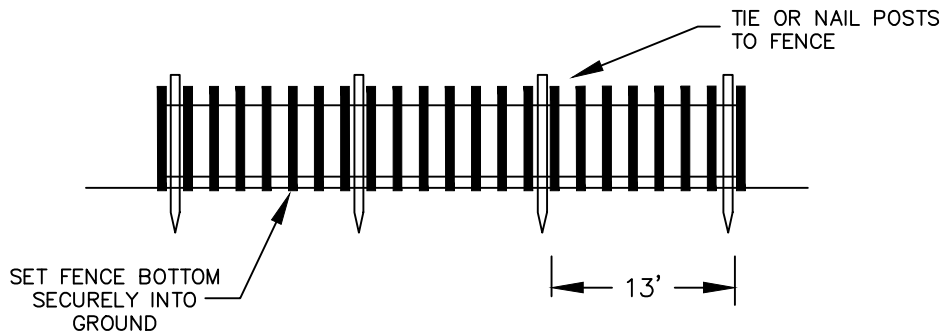

SAND FENCE

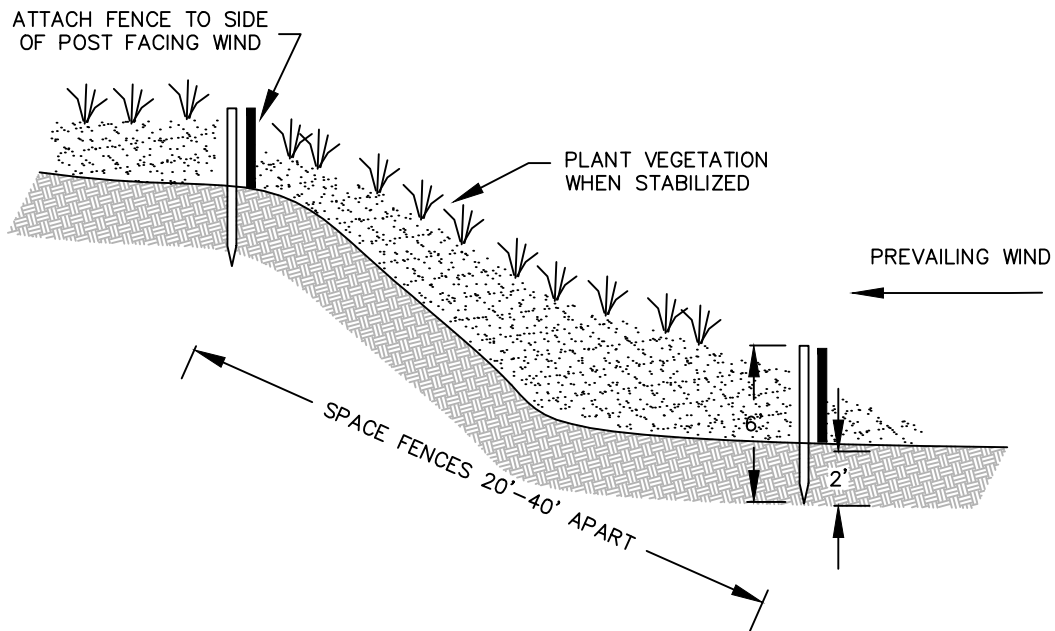

SAND FENCE CROSS-SECTION

APPLICATION

1. IN AREAS SUSCEPTIBLE TO WIND EROSION, PARTICULARLY WHERE THE GROUND HAS NOT YET BEEN STABILIZED THROUGH OTHER MEANS.
2. TO TRAP BLOWING SAND, REDUCING EROSION.
3. TO ASSIST IN STABILIZING OR RE-BUILDING A SLOPE.
4. USE ACROSS OPEN AREAS SUBJECT TO FREQUENT WIND, ALONG ROADS, JOB SITES, AND ADJACENT TO AGRICULTURAL FIELDS.

DESIGN

1. SAND FENCES ARE GENERALLY MADE UP OF WOODEN SLATS SPACED APPROXIMATELY 1.5 INCHES APART OR CONSIST OF PLASTIC WEB MATERIAL.
2. PLACE SAND FENCE PERPENDICULAR TO PREVAILING WIND DIRECTION.

DESIGN (CONT)

3. ANCHOR FENCE WITH STURDY POSTS AT LEAST 6 FEET LONG. DRIVE POSTS INTO THE GROUND APPROXIMATELY 2 FEET.
4. SPACE THE POSTS APPROXIMATELY 13 FEET APART. SPACING MAY BE ALTERED TO ENSURE POSTS ARE PLACED AT LOW POINTS.
5. SECURELY ATTACH SAND FENCE TO POSTS ON WINDWARD SIDE BY TYING OR NAILING FENCE MATERIAL TO EACH POST.
6. BE SURE THE BOTTOM OF THE FENCE IS SET SECURELY INTO THE GROUND.
7. AFTER THE ROW OF FENCE HAS ACCUMULATED SAND UP TO 2/3 ITS HEIGHT, ANOTHER ROW OF FENCE WILL NEED TO BE ERECTED.
8. PLANT VEGETATION TO STABILIZE THE SAND WHEN THE BUILDING PROCESS SLOWS SIGNIFICANTLY.



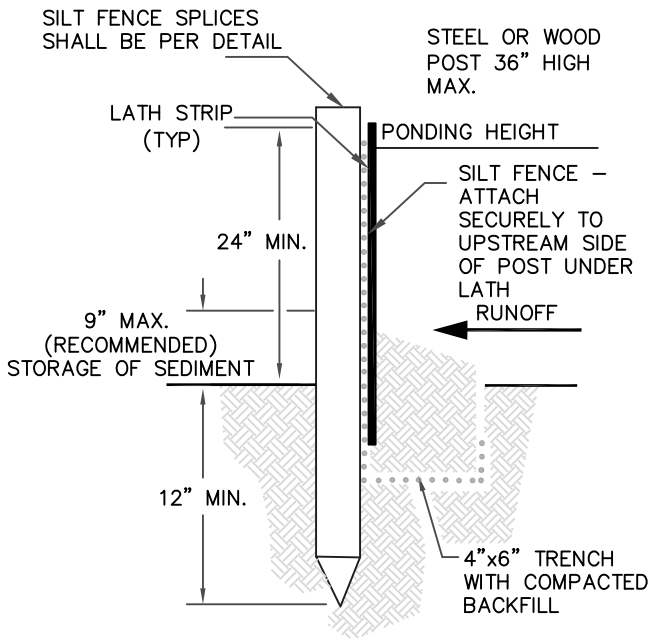
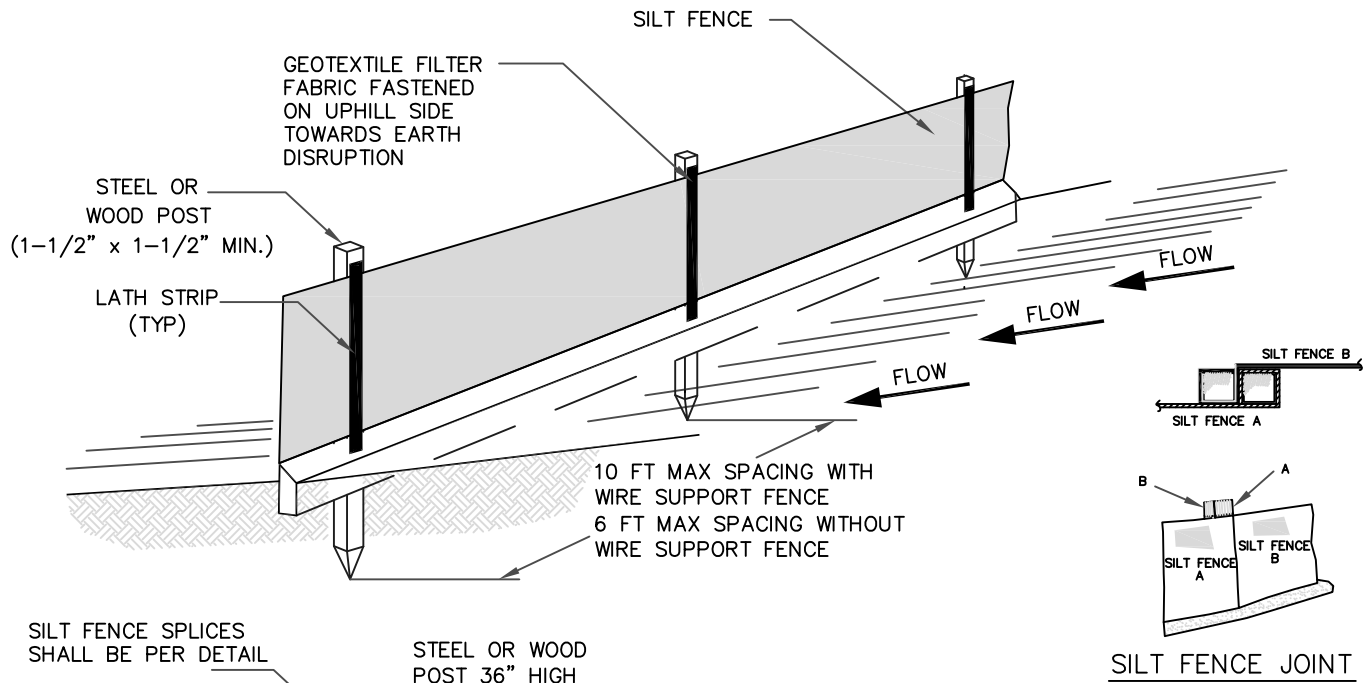

STANDARD DETAIL  
TRENCH WITH NATIVE BACKFILL

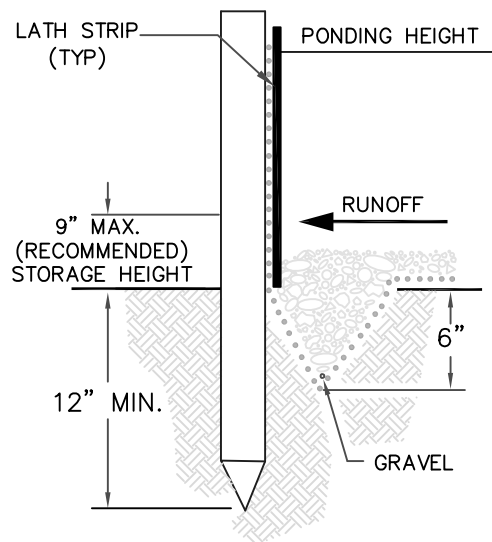

ALTERNATE DETAIL  
TRENCH WITH GRAVEL

APPLICATIONS

1. INSTALLED TO REDUCE SEDIMENT LADEN SURFACE RUNOFF FROM LEAVING THE PROPERTY OF A CONSTRUCTION SITE INVOLVING DISTURBED EARTH.
2. DIVERSIONARY STRUCTURE.

DESIGN

1. INSTALL AROUND THE BASE OF SOIL STOCKPILES.
2. UTILIZE FOR SHEET FLOW ONLY.

DESIGN (CONT)

3. INSTALL ON DOWN STREAM SIDE OF CONSTRUCTION.
4. SILT FENCE SHALL BE PLACED ON SLOPE CONTOURS TO MAXIMIZE PONDING EFFICIENCY.
5. IF POSSIBLE LOCATE FENCE 10-FT. FROM TOP OF SLOPE, WETLAND OR WATER BODY.
6. JOIN SECTIONS OF SILT FENCE BY WRAPPING THE ENDS TOGETHER.

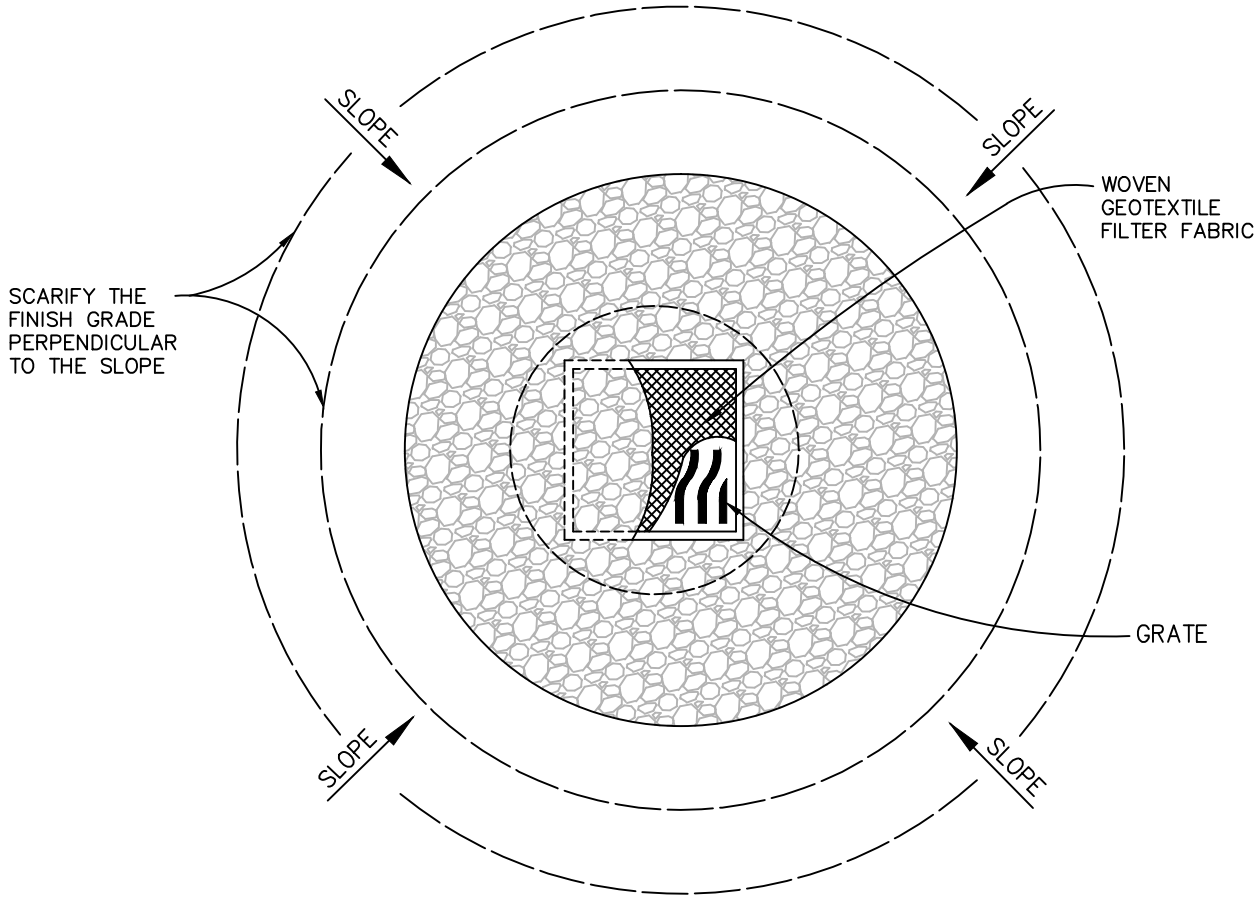

SECTION A-A

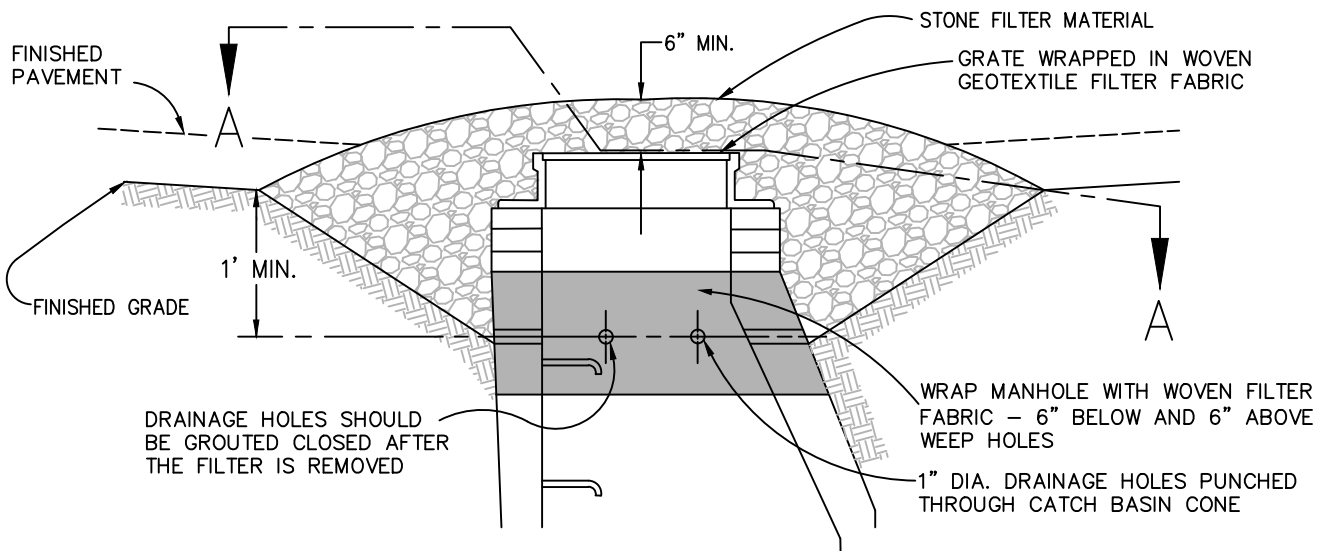

PROFILE VIEW

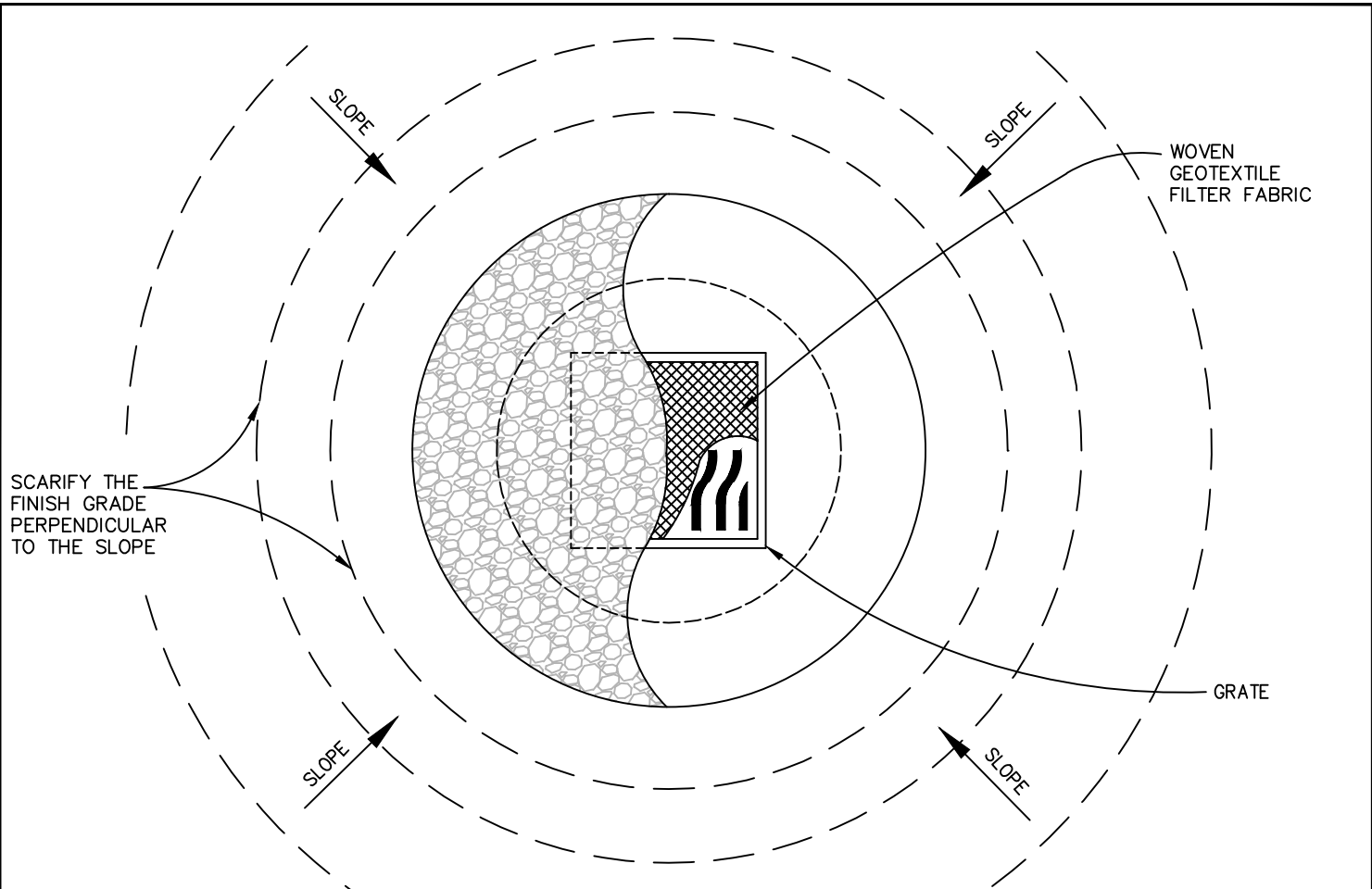

SECTION A-A

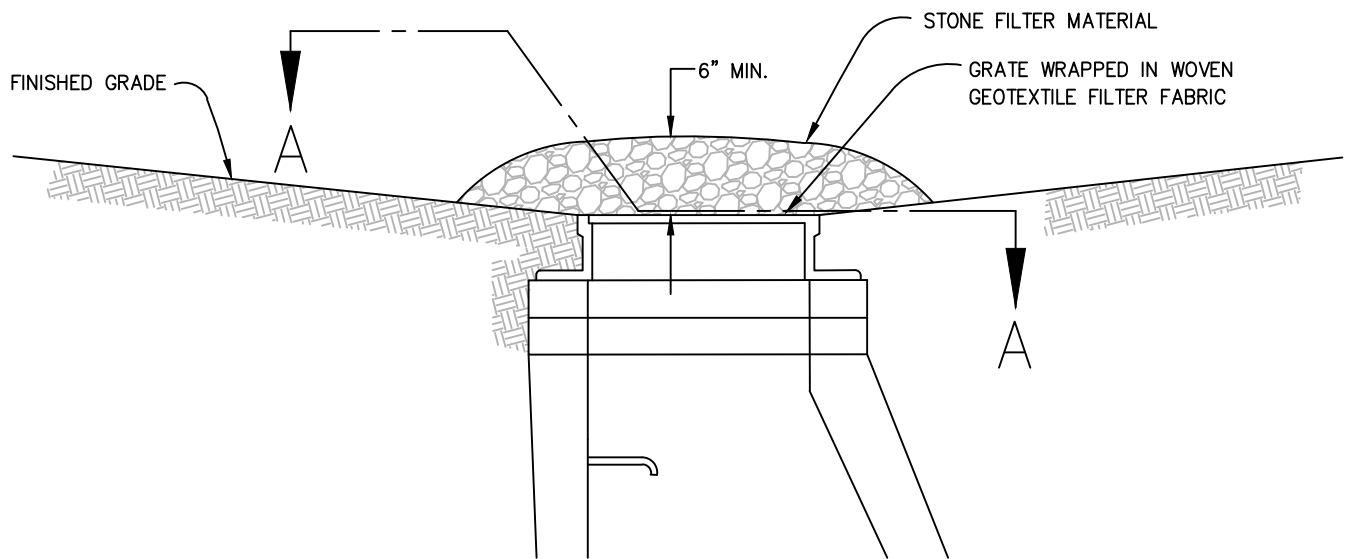

PROFILE VIEW

STONE INLET - AFTER PAVING 55A

THIS PAGE INTENTIONALLY LEFT BLANK

1 INCH TO 3 INCH LIMESTONE  
ON GEOTEXTILE FABRIC

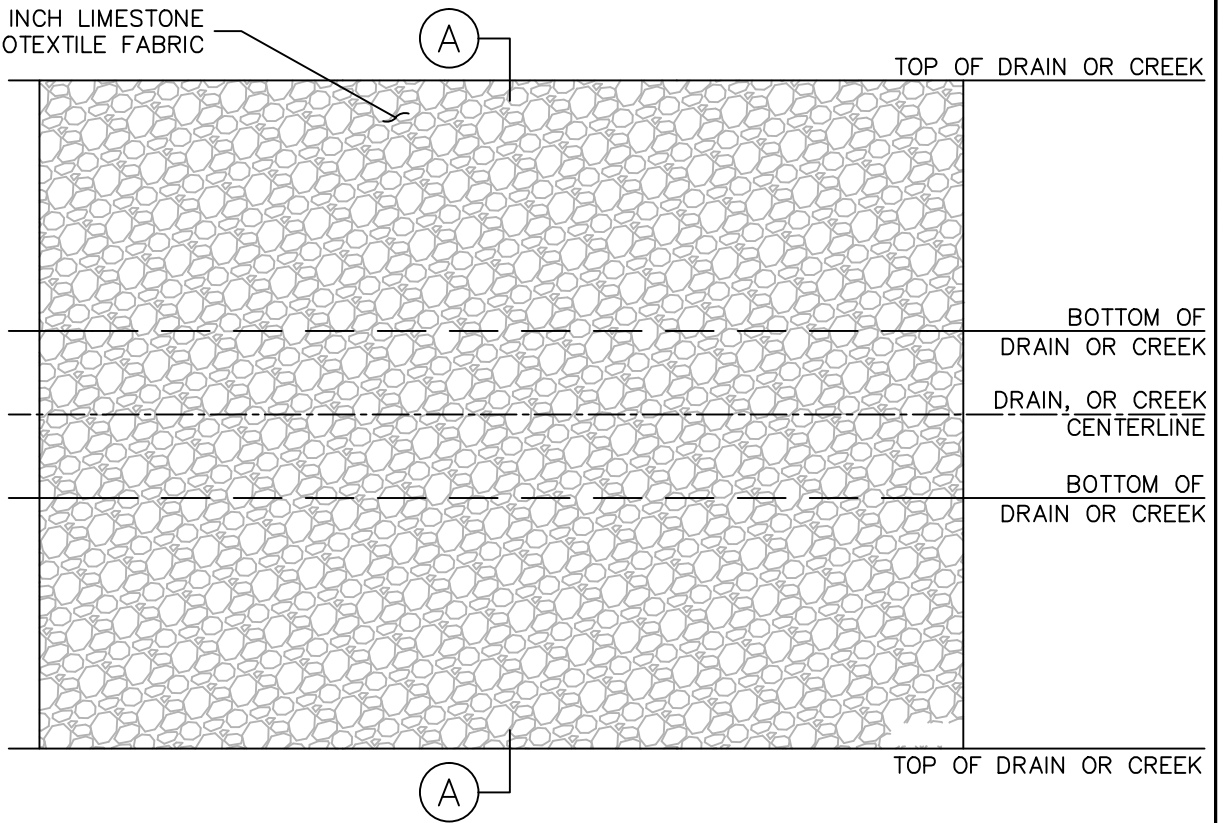

PLAN VIEW

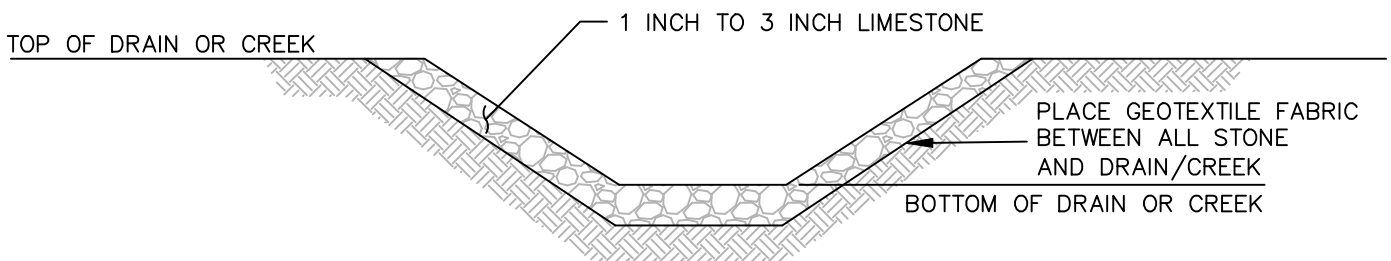

SECTION A-A

NOTES:

1. FORDING, DRIVING OR MOVING CONSTRUCTION EQUIPMENT OR VEHICLES THROUGH THE BED OF A DRAIN OR CREEK IS NOT PERMITTED AT ANY TIME.
2. TEMPORARY CROSSINGS SHALL BE REMOVED WITHIN TWO WEEKS OF THE WORK REACHING THE NEXT CROSS ROAD.
3. ALL STONE USED FOR THE TEMPORARY CROSSING SHALL BE REMOVED FROM THE DRAIN/CREEK.
4. SEED AND HIGH VELOCITY MULCH BLANKETS SHALL BE USED TO RESTORE DRAIN/CREEK BANKS. 3 TO 6 INCH SIZE STONE SHALL BE USED TO RESTORE THE BOTTOM OF THE DRAIN/CREEK.
5. CONTRACTOR ASSUMES ALL RESPONSIBILITY FOR DAMAGE DUE TO WET WEATHER FLOWS.

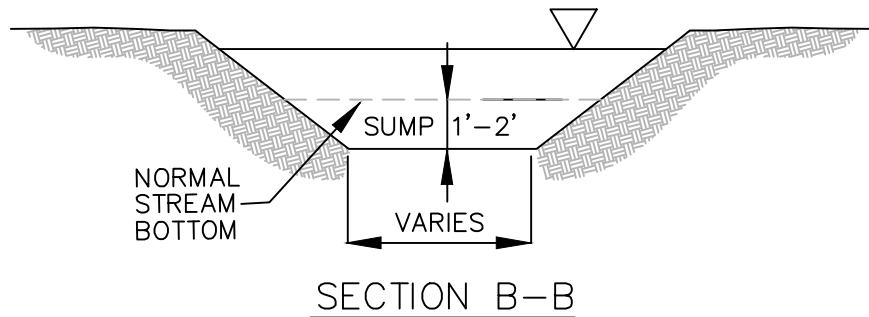
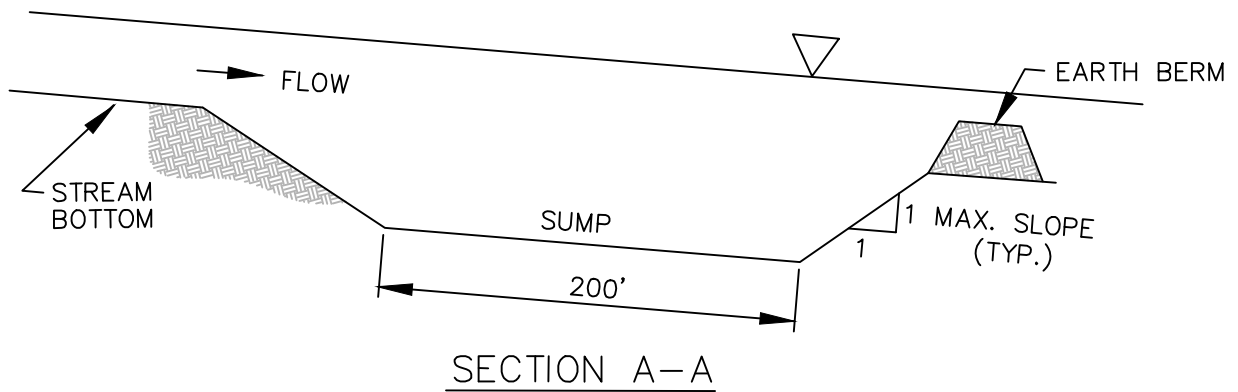
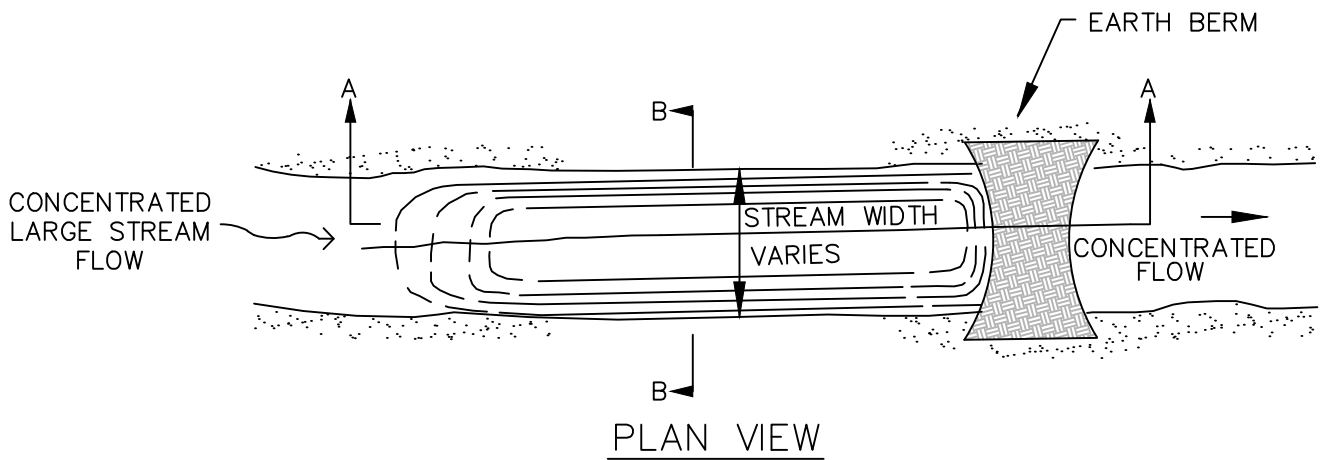

APPLICATIONS

1. CONTROLS SEDIMENTATION IN LARGE STREAMS.
2. WHERE CONCENTRATED FLOW CAN TRANSPORT SEDIMENTS.

DESIGN

1. OVER EXCAVATING THE DRAIN/STREAM BY ONE TO TWO FEET.
2. THE SUMP WILL BE AT LEAST 200 FEET LONG.
3. SEDIMENTS ACCUMULATED DURING CONSTRUCTION WILL BE REMOVED UPON PROJECT COMPLETION.

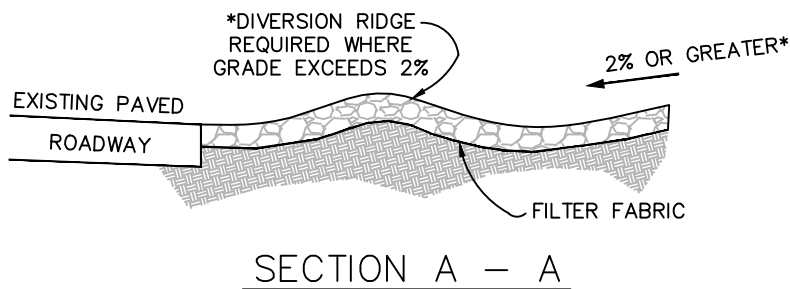
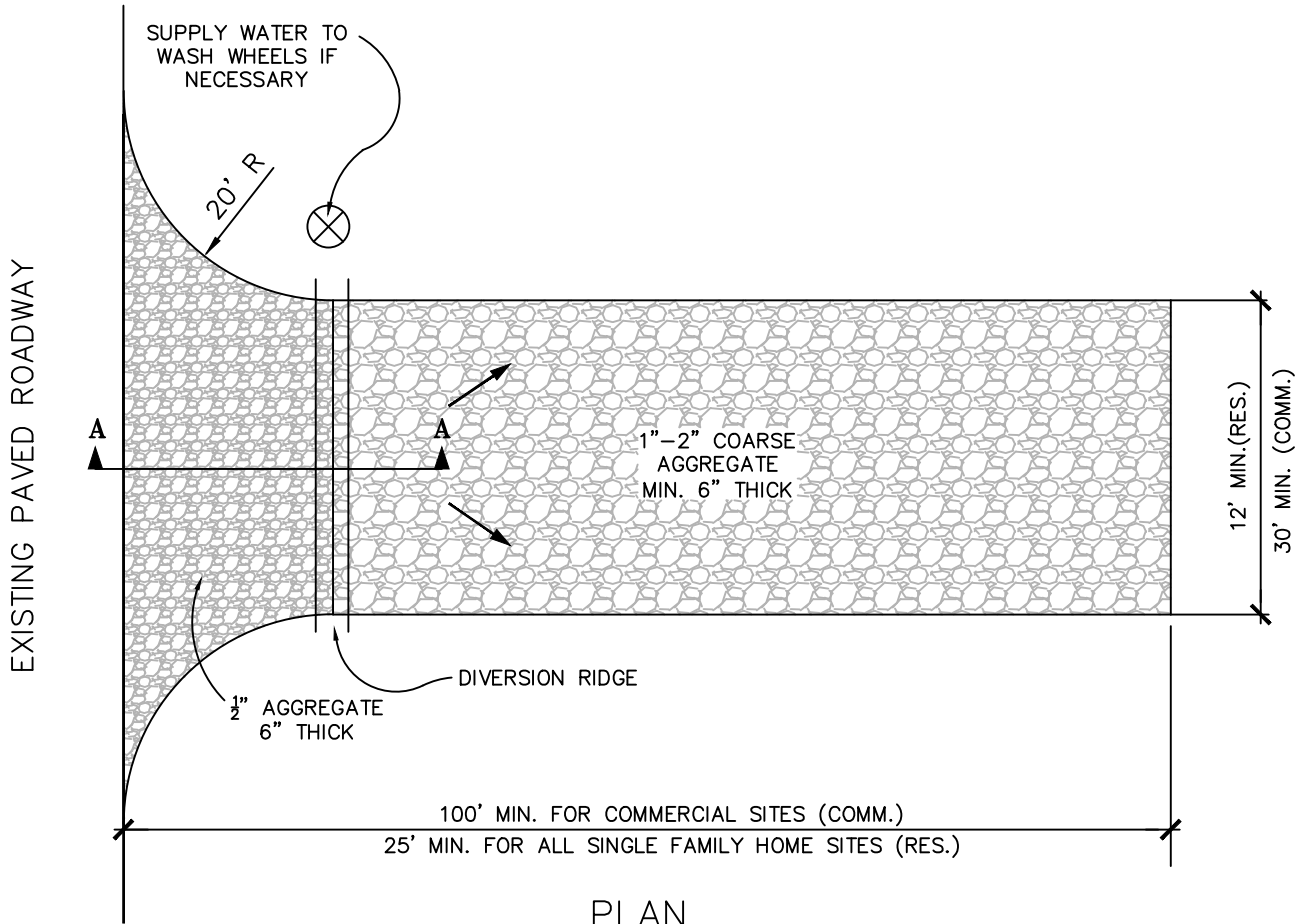

APPLICATIONS

1. ASSISTS IN REMOVING SOIL FROM THE TIRES OF CONSTRUCTION EQUIPMENT/VEHICLES WHEN EXITING THE CONSTRUCTION SITE. THIS REDUCES TRACKING EXCESSIVE SEDIMENT/SOIL ONTO THE ADJACENT ROAD.

DESIGN

1. THE ENTRANCE SHALL BE MAINTAINED IN A CONDITION THAT WILL PREVENT TRACKING OR FLOWING OF SEDIMENT ONTO PUBLIC RIGHTS-OF-WAY. THIS MAY REQUIRE TOP

DESIGN (CONT)

- DRESSING, REPAIR AND/OR CLEANOUT OF ANY MEASURES USED TO TRAP SEDIMENT.
2. WHEN NECESSARY, WHEELS SHALL BE CLEANED PRIOR TO ENTRANCE ON PUBLIC RIGHTS-OF-WAY.
  3. WHEN WASHING IS REQUIRED, IT SHALL BE DONE ON AN AREA STABILIZED WITH CRUSHED STONE THAT DRAINS INTO AN APPROVED SEDIMENT TRAP OR SEDIMENT BASIN.

## **PART 5: ADDITIONAL TABLES**



**Table 1. Seeding Dates for Permanent Mixtures**

<b>Spring Seeding Dates</b>	See note below regarding summer seeding	<b>Fall Seeding Dates</b>
April 1 – May 20		August 10 – October 1

Summer Seeding is reliable only if irrigation is available. If a project is completed in the summer and irrigation is not available, it is usually not feasible or advisable to delay seeding. Ensure that summer seeding is accompanied by an adequate thickness of properly anchored mulch. Even with the greatest care, follow up maintenance of summer seeding is more likely than for spring or fall seeding.

**Table 2. Seeding Dates for Native Grasses**

<b>Spring Seeding Dates</b>	<b>Fall Seeding Dates</b>
Thaw – June 30	November 1 – freeze/thaw

The spring seeding dates are preferred for maximum germination. Seed planted in summer will not develop adequately to survive winter. Fall seeding mimics natural systems and is effectively a dormant seeding.

**Table 3. Seeding Dates and Rates for Temporary Cover Crops**

Common Name	Seeding Rates		Seeding Dates
	Rates/Acre	Rate/1000 sq. ft.	
Oats	3 bushels	2 pounds	4/1 to 9/15
Barley	3 bushels	2 pounds	4/1 to 9/15
Annual Ryegrass	25 pounds	$\frac{3}{4}$ pounds	4/1 to 9/15
Sudangrass	35 pounds	1 pounds	6/1 to 7/15
Winter Wheat	2 bushels	1.5 pounds	9/20 to 10/15
Cereal Rye	2 bushels	1.5 pounds	8/1 to 10/15

Cereal rye and winter wheat will be destroyed by seedbed preparation at the next permanent seeding period. Cereal rye may inhibit the growth of other species.

***Key for Information in Tables 4,5 and 6***

Abbreviations for Soil Natural Drainage Classes – WD = Well Drained.

MWD = Moderately Well Drained, SPD = Somewhat Poorly Drained,

PD = Poorly Drained, VPD = Very Poorly Drained

Abbreviations for Suitable Uses (table 4) – A = sites maintained as a lawn; C/F = cut and fill, slopes, ditch banks; WW = areas subject to periodic storm water flow such as grassed waterways, ditch bottoms, diversions. Species shown in **bold face** may be invasive and should not be planted where they can escape into sensitive natural areas.

Mix #	Common Name	Natural Drainage Class Suitability	Suitable Uses	Rate lbs/acre
1	Creeping red fescue	WD, MWD	A, C/F, WW	40
2	Creeping red fescue White clover, red clover, or alfalfa	WD, MWD	C/F	30 4
3	<b>Smooth bromegrass</b> Creeping red fescue White clover, red clover, or alfalfa	WD, MWD	C/F	15 15 4
4	<b>Smooth bromegrass</b> Alfalfa	WD, MWD	C/F, WW	30 4
5	<b>Smooth bromegrass</b> Creeping red fescue	WD, MWD	C/F, WW	20 20
6	<b>Kentucky Bluegrass</b> Creeping red fescue	MWD	A, C/F	20 20
7	Creeping red fescue <b>Tall Fescue</b>	MWD	C/F, WW	20 20
8	Creeping red fescue Creeping bentgrass	MWD, SPD	A, C/F	40 1
9	<b>Smooth bromegrass</b> <b>Tall Fescue</b>	MWD, SPD	C/F, WW	20 20
10	<b>Smooth bromegrass</b> Timothy Red clover	MWD, SPD	C/F, WW	15 4 4
11	<b>Smooth bromegrass</b> Creeping red fescue <b>Kentucky Bluegrass</b> <b>Birdfoot trefoil</b>	MWD, SPD	C/F, WW	10 10 10 4
12	<b>Tall Fescue</b> Creeping bentgrass	SPD, PD	C/F, WW	40 1
13	<b>Tall Fescue</b> Alsike clover or <b>Birdfoot trefoil</b>	SPD, PD	C/F, WW	20 8
14	Redtop Timothy Alsike clover or <b>Birdfoot trefoil</b>	SPD, PD	C/F	2 5 2
15	<b>Tall Fescue</b> <b>Smooth bromegrass</b> Creeping bentgrass <b>Birdfoot trefoil</b>	SPD, PD	C/F, WW	12 12 1 6
16	<b>Tall Fescue</b> Redtop	SPD, PD, VPD	C/F, WW	20 2

**Table 4. Example Seeding Mixture for Introduced Species**

Mix #	Common Name	Natural Drainage Class Suitability	Suitable Uses	Rate lbs/acre
17	Redtop	PD, VPD	C/F	4
	Alsike clover or <b>Birdfoot trefoil</b>			2
18	Creeping red fescue	See note 1	C/F	8
	<b>Kentucky Bluegrass</b>			8
	Redtop			1
	Timothy			2
	Alsike clover			3
19	Creeping red fescue	See note 1	C/F, WW	6
	Redtop			1
	<b>Tall Fescue</b>			6
	<b>Smooth bromegrass</b>			6
	Alsike clover or <b>Birdfoot trefoil</b>			3
	White clover, red clover, or alfalfa			3

Table 4 continued on the following page; notes are found at the bottom of the table.

**Table 4. Example Seeding Mixtures for Introduced Species (continued)**

Five pounds of annual or perennial ryegrass may be added to any mixture if quick cover is desired.

**1** – These mixtures are suitable for large or linear projects where several soil types may be encountered but a single seed mixture is desired for the project.

Common Name	Scientific Name	Plant Type	Seeding Rate lbs/acre	Drainage Class Suitability	Notes
Creeping red fescue	<i>Festuca rubra</i>	grass			
Chewing red fescue	<i>Festuca rubra var. falax</i>	grass	40	WD, MWD, SPD	1
Tall fescue	<i>Festuca arundinacea</i>	grass	40	WD, MWD, SPD	1
Smooth bromegrass	<i>Bromus inermis</i>	grass	40	WD, MWD, SPD	1
Perennial ryegrass	<i>Lolium perrene</i>	grass	25	WD, MWD, SPD	
“Lathco” flatpea	<i>Lathyrus sylvestris</i>	legume	30	WD, MWD, SPD	2
Alfalfa	<i>Medicago sativa</i>	legume	15	WD, MWD	1, 4
Crownvetch	<i>Coronilla varia</i>	legume	25	WD, MWD	
Sweet clover	<i>Melilotus spp.</i>	legume	15	WD, MWD	3
Red Clover	<i>Trifolium pratense</i>	legume	15	WD, MWD, SPD	4, 5
White Clover	<i>Trifolium repens</i>	legume	15	WD, MWD, SPD	
Kentucky Bluegrass	<i>Poa pratensis</i>	grass	30	WD, MWD, SPD	
Orchardgrass	<i>Dactylis glomerata</i>	grass	10	MWD	1
Timothy	<i>Phleum pratense</i>	grass	10	MWD, SPD	
Redtop	<i>Agrostis alba</i>	grass		SPD, PD, VPD	
Creeping bentgrass	<i>Agrostis stolonifera</i>	grass		SPD, PD, VPD	6
Birdfoot trefoil	<i>Lotus corniculata</i>	legume	15	SPD, PD, VPD	
Alsike clover	<i>Trifolium hybridum</i>	legume	15	SPD, PD, VPD	

**Table 5. Seed Selection Guide for Custom Mixtures of Introduced Species**

Notes:

1. Species with shade tolerance. “Chewings” red fescue is most shade tolerant; Kentucky bluegrass is moderately shade tolerant.
  2. Perennial ryegrass should comprise no more than 20% of any mixture (approx. 5 lbs/acre).
  3. Crownvetch can be very invasive in open habitats; do not use where it can be spread into adjacent open areas.
  4. These species are suitable for sand and gravel pit and mine reclamation projects.
  5. Sweet clover grows tall and can shade out other species.
- One pound of creeping bent may be added to mixtures created for SPD, PD or VPD sites.

**Table 5B. Creating a Custom Seed Mixture**

The mixture must contain at least 50% grass seed. Select species based on the natural drainage class of the site. Multiply the pure stand-seeding rate of each species by the percentage of the mixture composed of the respective species. Below is an example of a seeding mixture of a seeding mixture of grasses and legumes selected for a well-drained site.

Species	Pure Stand Rate lbs/acre		Percent in Seed Mix	Species Rate in Mixture lbs/acre
Creeping Red Fescue	40	X	40%	16
Smooth bromegrass	40	X	30%	12
Perennial ryegrass	25	X	20%	5
White Clover	15	X	10%	1.5

Total lbs/acre = 34.5

**Table 6. Seed Selection Guide for Some Commonly Available Native Grasses**

Common Name	Scientific Name	Seeding Rate lbs/acre	Drainage Class Suitability	Notes
American beachgrass	<i>Ammophila breviligulata</i>		Dunes, WD sands	1
“Tioga” deertongue	<i>Panicum clandestinum</i>	15	WD, MWD	2,3
Little bluestem	<i>Schizachyrium scoparius</i>	12	WD, MWD	2
Big bluestem	<i>Andropogon gerardii</i>	15	WD, MWD, SPD	2
Switch grass	<i>Panicum virgatum</i>	10	WD, MWD, SPD	2
Indian grass	<i>Sorghastrum nutans</i>	10	WD, MWD, SPD	2

Notes:

- 1- Beachgrass is planted vegetatively; see text.
- 2- Warm season grasses.
- 3- Suitable for sand and gravel pit and mine reclamation.

A great variety of native species are available; consult suppliers for cultural information.

Note: Refer to the **Soil Survey of Genesee County** that is available for the United States Department of Agriculture regarding **drainage class suitability** of a particular soil type.

This document is derived from the Michigan Department of Environmental Quality's Guidelines for Vegetative Erosion Control